



**Montague Model V136-5 Heavy-Duty
Open Top Gas Range
Appliance Performance in Production**

Report 5011.93.7

FSTC Manager: Don Fisher

Production-Test Kitchen

Final Report, December 1993

Prepared by:

Richard Young

Contributor:

Catherine Cesio

Prepared for:

**Pacific Gas and Electric Company
Products and Services Department
444 Market Street, P.O. Box 770000
San Francisco, California 94177**

© 1993 by PG&E

**POLICY ON THE USE OF FOOD SERVICE TECHNOLOGY CENTER
TEST RESULTS AND OTHER RELATED INFORMATION**

- The FSTC is *strongly* committed to testing food service equipment using the best available scientific techniques and instrumentation.
- The FSTC is neutral as to fuel and energy source. It does not, in any way, encourage or promote the use of any fuel or energy source nor does it endorse any of the equipment tested at the FSTC.
- FSTC test results are made available to the general public through both PG&E technical research reports and publications provided by the *Kitchen Monitor* subscription service. All of these documents are protected under U.S. and international copyright laws.
- In the event that FSTC data is to be reported, quoted, or referred to in any way in publications, papers, brochures, advertising, or any other publicly available documents, the rules of copyright must be strictly followed, including written permission from PG&E *in advance* and proper attribution to PG&E and the Food Service Technology Center. In any such publication, sufficient text must be excerpted or quoted so as to give full and fair representation of findings as reported in the original documentation from FSTC.

PREFACE

Historically, performance testing of commercial cooking appliances has been conducted by food service equipment manufacturers and research organizations under controlled laboratory conditions. However, key decision makers in the food service industry have long seen a need to evaluate appliance performance under real-life conditions. Pacific Gas and Electric Company (PG&E) is providing this opportunity at its Food Service Technology Center (FSTC) in San Ramon, California.

The FSTC has three components. The first, the Production-Test Kitchen, is a unique combination of a real food service operation and a testing laboratory at PG&E's corporate Learning Center dining facility. As a testing lab, it is equipped to measure the energy consumed by gas and electric cooking appliances as they are used for menu production. As a production kitchen, operated by the staff of a contract food service management company, the 162-seat dining facility provides cafeteria-style breakfast and lunch and table service dinner for the students and staff at PG&E's Learning Center.

The second is a 6,700-square-foot appliance research laboratory, which complements the Production-Test Kitchen by supporting the development and application of standard methods of tests for commercial food service equipment. The laboratory also provides an arena for identification and investigation of environmental issues related to food service facilities.

Technology transfer is the third component, *Restaurants & Institutions* magazine publishes the results of FSTC research in a national subscription service called the *Kitchen Monitor*. Other technical reports produced by the FSTC are also available through the *Kitchen Monitor*. For more information write or call Corinne Zollars, *Kitchen Monitor*, 1350 East Touhy Avenue, Des Plaines, IL 60018 (708-390-2086; fax 708-635-6856).

ACKNOWLEDGMENTS

The establishment of a state-of-the art Food Service Technology Center reflects PG&E's commitment to the hospitality industry. The goal of the research project is to provide PG&E's food service customers with information to help them evaluate technically innovative cooking appliances and make informed equipment purchases regarding advanced technologies and energy sources. The project was the result of many people and departments working together within PG&E and the overwhelming support of the commercial equipment manufacturers who loan the cooking appliances for testing. Specific appreciation is extended to the Montague Company for supplying PG&E with a gas range for installation in the Production-Test Kitchen.

PG&E's Food Service Technology Center acknowledges the support of the project's National Advisory Group. Participating organizations from the research community include the Electric Power Research Institute (EPRI), the Gas Research Institute (GRI), the American Gas Association Laboratories (AGAL), and Underwriters Laboratories (UL). Representing end users are the National Restaurant Association, Restaurants & Institutions, McDonald's Corporation, General Mills Restaurants, and Marriott International. Academia is represented by The Pennsylvania State University.

EXECUTIVE SUMMARY

This study documents the performance and energy use of the 120,000-Btu Montague heavy-duty open top gas range cooktop, model V136-5, as it was used for routine menu production in PG&E's Production-Test Kitchen and during tests under controlled conditions. The range top has three 12-inch open tops with six open burners, and it is mounted on a convection oven base.

This report is one of a series of production reports which study the energy use of different Montague range cooktops mounted on the same convection oven base. The other reports cover the Montague V136-9E hot top range (report 5011.93.13) and the Montague V136-559 combination open top/hot top range (report 5011.93.8). The convection oven base was monitored for the V136-9E study, and therefore is not included in this report.

The range top production energy consumption and time of use were consistent from day to day, typically consuming 184 kBtu in 9.2 hours of operation. The average rate of production energy consumption was 20 kBtu/h.

The cooktop would consume an estimated 47,800 kBtu per year, or 478 therms, resulting in a total annual energy cost of \$278. This calculation is based on PG&E's G-NR1 rate schedule dated January 1, 1993 (gas, \$0.51/therm), and a year-round, five-day food service operation.

Controlled energy tests were conducted to supplement monitoring information acquired during actual production. The energy input rate for the range top was measured at 117.2 kBtu/h, with a pilot energy input rate of about 2.1 kBtu/h.

FSTC Manager



Donald R. Fisher

Technical Support
Supervisor



Peter W. Turnbull

CONTENTS

	Page
1 INTRODUCTION	1-1
OBJECTIVES	1-1
THE PRODUCTION CENTER	1-1
APPLIANCE DESCRIPTION AND INSTALLATION	1-3
2 CONTROLLED ENERGY TEST	2-1
PURPOSE	2-1
METHODS AND RESULTS	2-1
3 PRODUCTION MONITORING	3-1
ENERGY	3-1
ESTIMATED ANNUAL ENERGY COST	3-3
FOOD	3-4
OBSERVATIONS	3-4
4 CONCLUSIONS AND RECOMMENDATIONS	4-1
PRODUCTION	4-1
ENERGY CONSUMPTION AND CONSERVATION POTENTIAL	4-1
5 REFERENCES	5-1
Appendix A:	
GLOSSARY	
Appendix B:	
MANUFACTURER'S PRODUCT SPECIFICATIONS	
Appendix C:	
FREQUENCY DISTRIBUTION OF DATASET	
Appendix D:	
PG&E ENERGY RATES	

FIGURES

Figure		Page
1-1	Dining facility, PG&E Learning Center.....	1-2
1-2	The production center	1-2
2-1	Controlled energy test	2-2
3-1	Typical day energy consumption profile for cooktop.....	3-2

TABLES

Table		Page
1-1	Appliance Specifications.....	1-3
2-1	Summary of Controlled Energy Test	2-1
3-1	Average Daily Energy Performance	3-1
3-2	Estimated Annual Energy Cost	3-3

Section 1
INTRODUCTION

The Montague gas range, model V136-5, was selected for production energy monitoring and performance evaluation for PG&E's Production-Test Kitchen research program. It was used for routine menu production in PG&E's food service operation from February 1992 to January 1993. This report is the second in a series of three production reports which study the energy use of different Montague range cooktops mounted on the same convection oven base. The first report covers the Montague V136-9E hot top range and the third report covers the Montague V136-559 combination open top/hot top range.^{1,2} Because the convection oven base was monitored during study of the V136-9E, it is not included in this report.

Terms used in this report are defined in Appendix A.

OBJECTIVES

This study documents the energy consumption patterns of the Montague gas range cooktop as it was used during daily food production and during tests under controlled conditions. Also reported are typical uses of the range top, the estimated annual energy consumption, and the cost to operate.

THE PRODUCTION CENTER

The 1,500-square-foot kitchen is an integral component of the campus-style dining facility at PG&E's Learning Center (Figure 1-1). Nine cooking appliances are centrally located on two sides of a utility distribution system (UDS; Figure 1-2). The UDS functions as a central "spine" that contains all plumbing, wiring, and natural gas distribution lines. A 16-foot, double-sided canopy exhaust hood ventilates the equipment island at a design air flow of 9,600 cfm. Grilles along the front face of the hood direct makeup air into the kitchen.

The production center was designed to accommodate quick connection and disconnection of the appliances as they are rolled in or out of the "line," with the flexibility to accommodate either a gas or an electric model in each appliance slot. Gas and electric meters interface with a remote data acquisition and processing system. Appliance monitoring and performance evaluations are conducted by an interdisciplinary research team, independent of the food service operation.

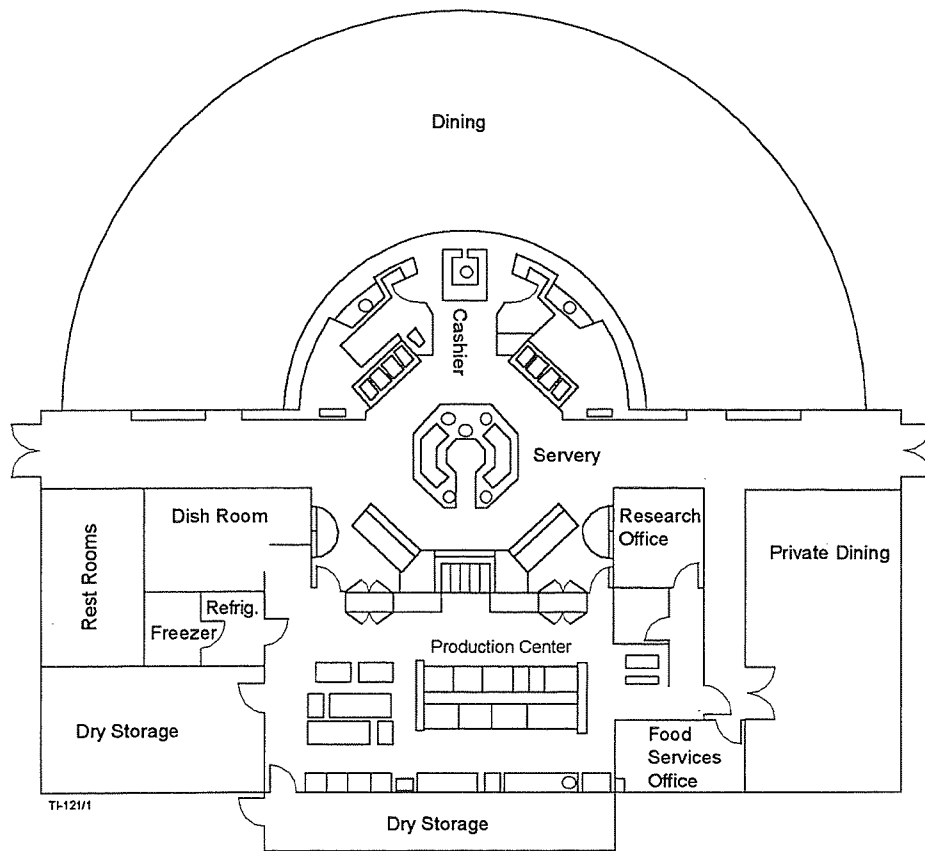

Figure 1-1. Dining facility, PG&E Learning Center.

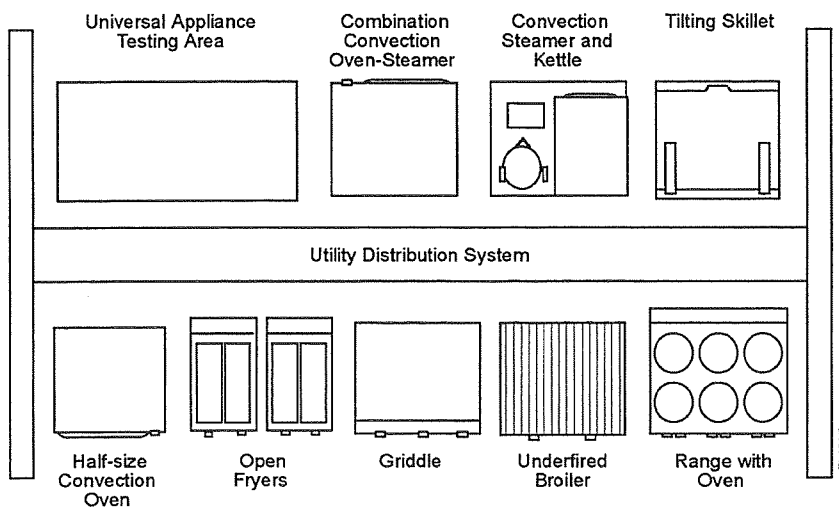

Figure 1-2. The production center.

APPLIANCE DESCRIPTION AND INSTALLATION

The 120,000-Btu/h gas range cooktop includes three 12-inch open tops with six open burners. Appliance specifications are given in Table 1-1. The manufacturer's specification sheet is in Appendix B.

Cooking utensils are supported by heavy-duty burner grates above the star type burners. Each burner is manually controlled by a front-mounted control knob. Six standing pilots provide burner ignition.

Table 1-1
Appliance Specifications

Generic Appliance Type:	36" all-purpose open top range cooktop
Manufacturer:	The Montague Company
Model:	Legend V136-5
Rated Input:	120,000 Btu/h (range cooktop only)
Dimensions:	36" wide by 36-5/8" deep by 34-1/2" high (to work surface)
Construction Material:	Steel with a stainless-steel front

Section 2
CONTROLLED ENERGY TEST

PURPOSE

The purpose of conducting energy tests under controlled, or lab-style, conditions is to:

1. Verify that the appliance operates at the manufacturer's rated energy input.
2. Characterize preheat and idle energy use under select operating conditions.

METHODS AND RESULTS

Cooktop Test

The researchers operated the six burners at the maximum setting for a 15-minute stabilization period, after which all of the burners operated for a 10-minute test period. At the end of every 10 minutes, one burner was turned off until only the pilots were operating. The left front burner was the first to be turned off, and the pattern continued front-to-back and left-to-right, ending with the right rear burner. The six pilots were operating during the entire test. The test results are summarized in Table 2-1. Figure 2-1 shows the energy consumption rates as the number of burners was reduced from six to one.

Table 2-1
Summary of Cooktop Controlled Energy Test

	Number of Burners					
	6	5	4	3	2	1
Rated Energy Input Rate (kBtu/h):	120.0	100.0	80.0	60.0	40.0	20.0
Measured Energy Input Rate (kBtu/h):	117.2	98.4	79.5	60.0	38.7	19.2
Idle Energy Consumption Rate (kBtu/h):	117.2	98.4	79.5	60.0	38.7	19.2
Idle Duty Cycle (%):	100.0	100.0	100.0	100.0	100.0	100.0
Pilot Energy Input Rate (kBtu/h):	2.1	2.1	2.1	2.1	2.1	2.1

The cooktop does not have a defined preheat time because the burners produce instantaneous heat, which allows immediate heating of a food load.

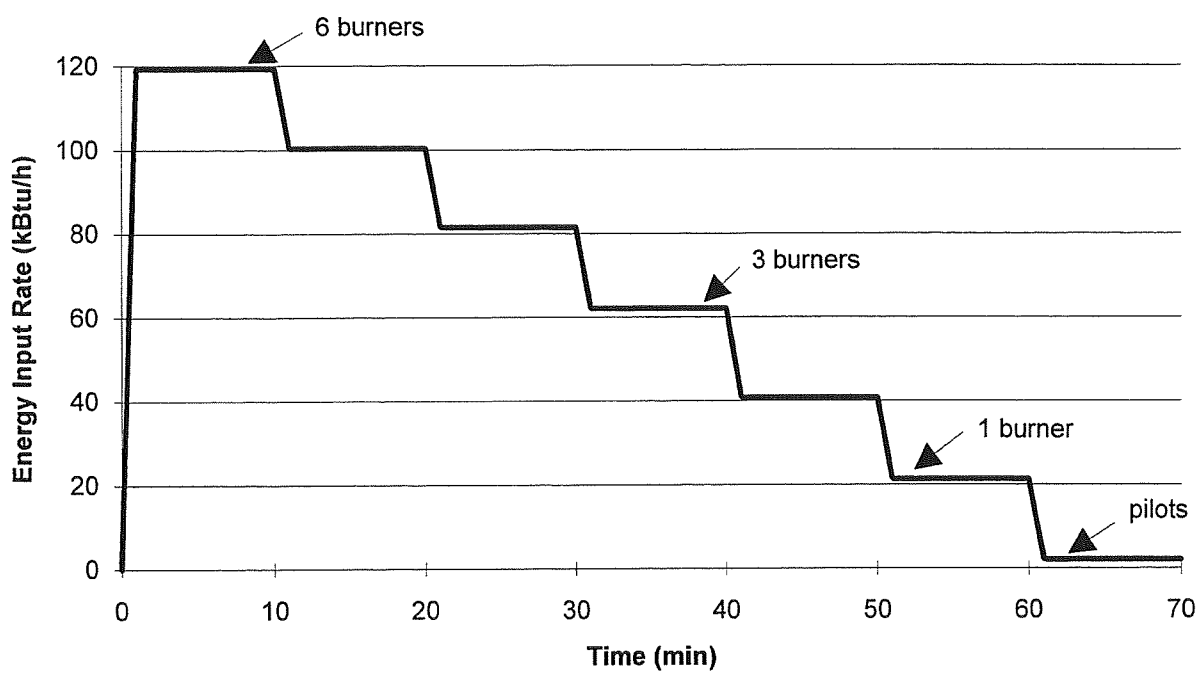

The six pilots were continuously operating during the test.

Figure 2-1. Controlled energy test.

Section 3
PRODUCTION MONITORING

7 mo. ?

ENERGY

The researchers used data gathered from February to August 1992 to quantify typical day characteristics. All Fridays, Saturdays, Sundays, and holidays were eliminated because they were not three-meal food service days. The range cooktop dataset was reduced to 72 days. The average daily energy performance of the range cooktop is summarized in Table 3-1.

Table 3-1
Average Daily Energy Performance

INTEGRATED }	Daily Energy Use: ^a	210 kBtu/d
	Daily Production Energy Use: ^b	184 kBtu/d
	Pilot Only Energy Use:	26 kBtu/d
	Appliance On Time:	9.2 h/d
	Average Production Energy Consumption Rate: ^b	20 kBtu/h
	Measured Peak Energy Input Rate:	117.2 kBtu/h
	Duty Cycle:	17 %
	Total Pilot Energy Use: ^c	43.2 kBtu/d
	Pilot Energy Consumption Rate:	1.8 kBtu/h

^aIncludes pilot energy consumption during periods when the range was not in use.
^bIncludes pilot, preheat, and idle energy over the hours of operation when the range was in use.
^cIncludes total energy consumed by the standing pilot over the full 24-hour day.

The energy consumption profile shown in Figure 3-1 illustrates the typical day production energy use for the range cooktop. The staff used at least one of the cooktop burners shortly after they arrived in the morning and continued to use one or more burners throughout the morning and into the lunch hour. The majority of the daily production energy use occurred during these morning prep hours, as the staff cooked large stockpots of hot cereal, soups and sauces, gravy, and chili for breakfast, lunch, and dinner. All the burners were turned off during lunch and were not used again until the early afternoon for the final dinner prep. During dinner, up to three of the burners were operated as needed for cook-to-order items or sauté.

The frequency distributions for daily production energy use and hours of operation for the range cooktop are presented in Appendix C.

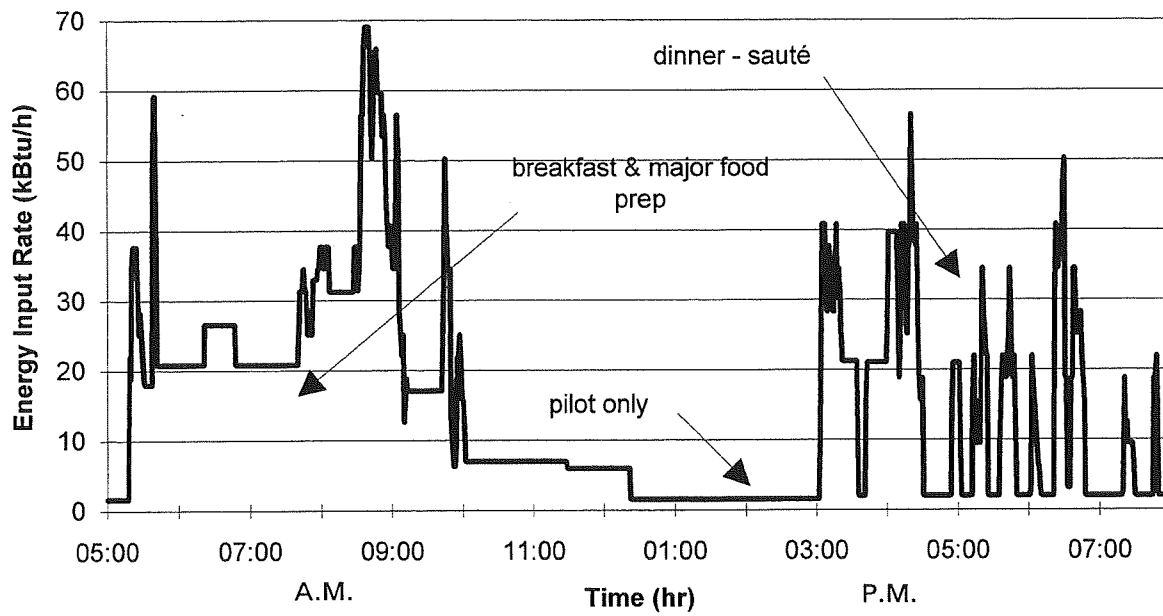

Figure 3-1. Typical day energy consumption profile.

ESTIMATED ANNUAL ENERGY COST

The range cooktop would consume approximately 478 therms per year during food production and 68 therms per year during pilot-only operation; the total energy usage would be 546 therms based on a year-round (52 week) five-day food service operation. At a cost of \$0.51/therm, the total cost to operate the cooktop would be \$278: production accounts for \$244, and non-production pilot operation accounts for \$34. These costs of operation, as shown in Table 3-2, were calculated using PG&E's average gas rate (Schedule G-NR1) for small, non-residential customers (Appendix D).

Table 3-2
Estimated Annual Energy Cost

Production Energy Charge for Cooktop (478 therms per year x \$0.51/therm):	\$244
Energy Charge for Pilot-Only Operation (68 therms per year x \$0.51/therm):	34
Total Energy Charge for Cooktop (546 therms per year x \$0.51/therm):	278

Note: (1) 1 therm = 100 kBtu.

(2) Estimates are based on PG&E's G-NR1 rate schedule for gas in effect January 1, 1993 (Appendix D). These estimates do not include customer charges.

FOOD

Items Cooked

A researcher observed the range usage during several periods of normal operation, interviewed the cooks, and reviewed the cooks' daily worksheets to get a good idea of the variety of food items prepared on the cooktop. The cooks primarily used the range cooktop for stockpot cooking, stir-frying, and sautéing of breakfast, lunch, and dinner menu items. Typical foods cooked included hot cereals, gravies, sauces, soups and chowders, chili, and vegetables.

Quantity Cooked

The quantity of food cooked was estimated based on daily worksheets filled out by the cooks. On a typical day, the cooks prepared about 100 pounds of food on the range cooktop.

Previous investigation has found no significant correlation between the daily quantity of food cooked with a range and its daily energy consumption.³

Customer Count

The average customer count was 550 for the period that the range cooktop was in production. As with the quantity of food cooked, there is no significant correlation between the daily customer count and daily energy consumption.³

OBSERVATIONS

Usage of the range cooktop was often heaviest during the early morning hours, when the cooks heated a large pot of water for cereal and prepared a large pot of gravy. They might also need to heat water for other uses, such as the steam tables or for poaching eggs. If they served eggs Benedict, they prepared the hollandaise sauce on the cooktop. For the rest of the day, the operators would use the cooktop for a few heavy loads, such as large batches of soup, and various lighter loads, such as glazes or sauces. Depending on the dinner menu, the cooktop usage might involve sautéing ingredients, such as mushrooms or onions, and preparing dinner items, such as ravioli in cream sauce or scallops in butter and herb sauce.

CONCLUSIONS AND RECOMMENDATIONS

PRODUCTION

The cooks found the range easy to operate and clean and flexible enough to meet their preparation needs, from simmering to sautéing. The six open burner cooktop was a good match for this operation; all six burners were needed for peak production. The staff tended to use the front three burners for most short-term cooking and the rear three for longer tasks, such as heating a large batch of soup and holding it at a simmer. Being able to slide pots from one burner to another without lifting them was an advantage the staff greatly appreciated.

ENERGY CONSUMPTION AND CONSERVATION POTENTIAL

Because the range usage at PG&E's Learning Center dining facility is typical of food service operations catering to a mixed customer base, the opportunities for reducing energy costs pertain to other operations as well. A range cooktop can save energy through efficient operation.

No significant energy savings can be gained by more efficient operation of this cooktop because the Learning Center cooks used it in the most efficient way. The staff did two things which ensured that the range did not use unnecessary energy; they turned off any unused burners, and they did not modify the burner orifice. Since a burner has no preheat time, it should be operated only when needed. Leaving a burner on when there is nothing being cooked on it is a waste of energy. At some food service operations, especially those with open kitchens, operators have been known to modify the burners by enlarging the orifices to get a more dramatic flame. The lazy yellow flames produced by a drilled-out burner direct less heat into the cooking process, which means that more heat is wasted up the hood.

This particular food service operation is considered a good match for this range cooktop. The open-burner-style cooktop is cost effective at \$278 per year compared to \$811 for the hot top cooktop which was installed previously.¹

Section 5

REFERENCES

1. Pacific Gas and Electric Company. 1993. *Montague Model V136-9E Heavy-Duty Gas Range: Appliance Performance in Production*. Products and Services Report 5011.93.13, Pacific Gas and Electric Company, San Francisco, California.
2. Pacific Gas and Electric Company. 1993. *Montague Model V136-559 Heavy-Duty Gas Range: Appliance Performance in Production*. Products and Services Report 5011.93.8, Pacific Gas and Electric Company, San Francisco, California.
3. Pacific Gas and Electric Company. 1990. *Appliance Performance Report: Vulcan-Hart Electric Range, Model VR-4*. R&D Report 008.1-90.24, Pacific Gas and Electric Company, San Ramon, California.

Appendix A
GLOSSARY

GLOSSARY

Appliance On-Time (minute, hour)

Hours of Operation

Operating Period

Operating Time

The total period of time that an appliance is operated (from the perspective of food service staff) from the time it is turned “on” to the time it is turned “off.” Appliance on-time excludes any “off” periods between the first and last appliance operation.

Average Daily Production Energy Consumption Rate (kW or kBtu/h)

The average rate of production energy consumption based on the daily production energy consumption and the appliance operating or “on” time.

$$\text{Average Daily Production Energy Rate} = \frac{\text{Daily Production Energy Consumption}}{\text{Appliance On - Time}}$$

Note: By basing the total daily production energy consumption on a 24-hour period, the total quantity of pilot energy (if applicable) is considered within the average production energy consumption rate and is based on the actual period of appliance usage.

Average Production Energy Consumption Rate (kW or kBtu/h)

Average Production Energy Rate

Average Production Energy Use Rate

The average rate of production energy consumption based on the production energy consumption and the appliance operating or “on” time for a specified period of appliance operation.

$$\text{Average Production Energy Consumption Rate} = \frac{\text{Production Energy Consumption}}{\text{Operating Time}}$$

Baseload Energy Consumption (kWh or kBtu)

Baseload Energy

The total amount of energy that would be consumed over the operating period of an appliance if it had never been used to cook food.

Baseload Energy Consumption Rate (kW or kBtu/h)

Base Rate

Baseload Energy Rate

Baseload Rate

The lowest rate of energy consumption reflected by the energy consumption profile (based on a 15-minute sliding window average) recorded during appliance operation. Generally, this definition is not extended to include the rate of pilot energy consumption. It is typically equal to the lowest value of idle energy consumption rate.

Cold Zone

The volume in the fryer below the heating element(s) or heat exchanger surface designed to remain cooler than the fry zone and hot zone.

Cook Zone

Cooking Zone

The volume of oil in the fryer where the fries are cooked. Typically, the entire volume from the heating element(s) of a heat exchanger surface to the surface of the frying medium.

Cooking Energy Consumption (kWh or kBtu)

The total energy consumed by an appliance during the cooking period.

Cooking Energy Consumption Rate (kW or kBtu/h)

The average rate of energy consumption during the cooking period.

Cooking Energy Efficiency

The quantity of energy input to the food products; expressed as a percentage of the quantity of energy input to the appliance during the heavy-, medium-, and light-load test.

Cooking Period (minute, hour)

The period of time (derived from in-kitchen monitoring or by interpreting the energy consumption profile) that an appliance is actually used for cooking.

Daily Energy Consumption (kWh or kBtu)

Daily Energy Use
Daily Production Energy Consumption
Daily Production Energy Use

The total amount of energy consumed by an appliance as it is used within the Production-Test Kitchen over a 24-hour period.

Note: By basing the total daily production energy consumption on a 24-hour period, the total quantity of pilot energy (if applicable) is considered within the average production energy consumption rate.

Duty Cycle (%)

Load Factor
Production Energy Factor
Production Factor

The average production energy consumption rate (based on a specified operating period for the appliance) expressed as a percentage of the measured energy input rate.

$$\text{Duty Cycle} = \frac{\text{Average Production Energy Consumption Rate}}{\text{Measured Energy Input Rate}} \times 100$$

Energy Consumption Profile

Energy Use Profile

A plot of appliance energy consumption showing energy consumption rate on the Y-axis and time on the X-axis.

Note: The area under the curve (plot) represents the total energy consumption for the period of integration. For uniformity in production reports, use the following terms and units for the coordinate labels:

y-axis: Energy Rate (kW or kBtu/h)

x-axis: Time (AM & PM): (Hour) (Min)

Energy Consumption Rate (kW or kBtu/h)

Energy Input Rate
Energy Rate

The rate of appliance energy consumption over a specified period of operation (see Energy Consumption Profile).

Energy Use Data Set

A set of daily energy consumption data compiled in accordance with typical day criteria.

Hot Zone

The area surrounding the heating element(s) or heat exchanger surface.

Idle Energy Consumption (kWh or kBtu)

Idle Energy Use

The amount of energy consumed by an appliance operating under an idle condition over the duration of an idle period.

Idle Energy Consumption Rate (kW or kBtu/h)

Idle Energy Input Rate

Idle Energy Rate

Idle Rate

The rate of appliance energy consumption while it is “idling” or “holding” at a stabilized operating condition or temperature.

Idle Duty Cycle (%)

Idle Energy Factor

Idle Load Factor

The idle energy consumption rate expressed as a percentage of the measured energy input rate.

$$\text{Idle Energy Factor} = \frac{\text{Idle Energy Consumption Rate}}{\text{Measured Energy Input Rate}} \times 100$$

Idle Temperature (°F, Setting)

The temperature of the cooking cavity/surface (selected by the appliance operator or specified for a controlled test) that is maintained by the appliance under an idle condition.

Idle Time (minutes, hour)
Idle Period

A period of time that an appliance is consuming energy at its idle energy consumption rate while maintaining a specified stable operating condition or temperature.

Note: Idle time may include both necessary or unnecessary appliance “idling.” This is simply differentiated by applying the appropriate adjective to the idle energy period term (e.g., needless idle time, necessary idle period.)

Measured Energy Input Rate (kW, W or kBtu/h, Btu/h)
Measured Input
Measured Peak Energy Input Rate
Peak Rate of Energy Input

The maximum or peak rate at which an appliance consumes energy, measured during appliance preheat or while conducting a water-boil test (i.e., the period of operation when all burners or elements are “on”).

Pilot Energy Consumption (kBtu)
Pilot Energy Use
Standing or Constant Pilot Energy Consumption
Standing or Constant Pilot Energy Use

The amount of energy consumed by the standing pilot of an appliance over a specified period of time.

Pilot Energy Rate (kBtu/h)
Average Pilot Energy Rate
Average Pilot Energy Use Rate
Pilot Energy Consumption Rate

The rate of energy consumption by the standing or constant pilot while the appliance is not being operated (i.e., when the thermostats or control knobs have been turned off by the food service operator).

Preheat Energy Consumption (kWh or kBtu)
Preheat Energy

The total amount of energy consumed by an appliance during the preheat period.

Note: The reporting of preheat energy must be supported by the specified temperature/operating condition.

Preheat Energy Rate

The rate of appliance energy consumption while it is “preheating” to a predetermined temperature.

Preheat Time (minute, hour)

Preheat Period

The time required for an appliance to “preheat” from the ambient room temperature ($75 \pm 5^\circ\text{F}$) to a specified (and calibrated) operating temperature or thermostat set point.

Production Day

Production Period

The time period when an appliance is used by the kitchen staff, typically between the hours of 5 A.M. and 8 P.M.

Production Energy Consumption (kWh or kBtu)

Production Energy Use

The total amount of energy consumed by an appliance as it is used within the Production-Test Kitchen over a specified time period (e.g., 10 A.M. to 1 P.M., dinner period). Production energy consumption is numerically equal to daily energy consumption if the production period is not specified.

Note: This integrated energy use includes preheat energy, idle energy, and pilot energy associated with the specified time period.

Rated Energy Input Rate (kW, W or kBtu/h, Btu/h)

Input Rating (ANSI definition)

Nameplate Energy Input Rate

Rated Input

The maximum or peak rate at which an appliance consumes energy as rated by the manufacturer and specified on the nameplate.

Typical Day

A selected day of energy usage based on predetermined criteria that will generate a production energy consumption profile reflecting typical production usage for a specific appliance. The typical day criteria may comprise:

- Typical day energy consumption should approximate average daily energy consumption for energy use data set.
- A specified number of appliance operations and/or cooking periods (e.g., lunch and dinner only).
- A specified range in operating hours.
- A specified mode of operation (or combination of modes) may be associated with a typical day's operation.

Appendix B
MANUFACTURER'S PRODUCT SPECIFICATIONS

MONTAGUE **LEGEND** Gas Heavy Duty Range — 136-5

ITEM NO.:

JOB I.D. NO.:

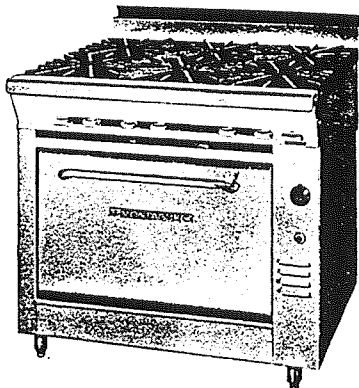

Model 136-5

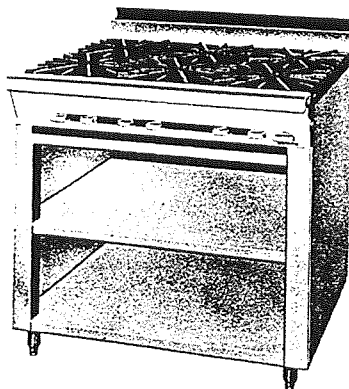

Model 36-5

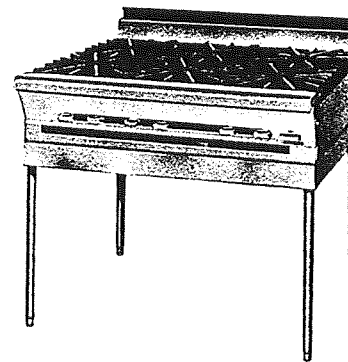

Model M36-5

Model Variations:

136-5 — Oven model with 6" legs.

36-5 — Cabinet model with 6" legs.

M36-5 — Countertop model with 28" high modular stand with S/S tubular legs.

C36-5 — Counter model without legs.

*4" legs (Optional. *Must be factory installed.*)

Open Tops: Three 12" wide x 31" deep heavily ribbed cast iron grates. Six each open burners. Each Star burner has individually raised ports to help prevent clogging from spillovers and for better combustion. Burners are rated at 20,000 BTU/HR each, with automatic constant burning pilots. Drip pan under open burners.

Options, *(extra cost):

- 59 top(s), rated @ 15,000 BTU/HR each, 12" wide x 31" deep cast iron top with heavily ribbed open burner grate across front and Solid Hot Top section across rear. Located:
 - 1, right 1, center 1, left

*Ribbon Grate, cast iron. (In-lieu-of 12" open burner grate.)

Note: For use with 20,000 BTU/HR burners. Located:

- *1, right *1, center *1, left

*30,000 BTU/HR Star open burner for use with Natural gas:

- *3, front *3, back *6, front and back

Oven Interior: The front venting oven is 26" wide x 28" deep x 15" high. Standard interior finish is porcelainized steel.

Options, *(extra cost):

- *Catalytic continuous cleaning interior (CCL)
- *Cast iron oven bottom

The 3-position rack guides and oven bottom are removable for major cleaning. The oven is heated by a cast iron burner rated at 40,000 BTU/HR. The oven cavity is completely encased in high density fiberglass insulation maximizing heat retention. One rack with bright nickel finish is furnished.

Oven Controls: Includes manual burner valve, heavy duty throttling type thermostat, 100% safety pilot and automatic

lighting. Controls are located in an insulated and vented compartment for longer life. Thermostat located on front right side. Thermostat dial has a temperature range from low to 500°F (260°C).

Oven Doors: Weight counterbalanced without the use of springs. One piece offset tubular-type handle is used.

Finish: Satin finish stainless steel front, including 4" flue riser. Remaining exterior black. All painted surfaces have electrolytic zinc undercoating for corrosion protection and longer life. Additional S/S finish available, *(extra cost):

- *S/S left side *S/S right side *S/S back panel
- *S/S lower shelves for cabinet base, (2 ea. required)

NOTE: Black finish with S/S trim available.

Options, *(extra cost):

- | | S/S front | Black |
|---|--------------------------|--------------------------|
| <input type="checkbox"/> *18" High Back: | <input type="checkbox"/> | <input type="checkbox"/> |
| <input type="checkbox"/> *Single High Shelf: | <input type="checkbox"/> | <input type="checkbox"/> |
| <input type="checkbox"/> *Double High Shelf: | <input type="checkbox"/> | <input type="checkbox"/> |
| <input type="checkbox"/> *Doors for Cabinet Base: | <input type="checkbox"/> | <input type="checkbox"/> |

*Extra Oven Racks

*42" Range Depth, suffix -40

*Left Rear Manifold with pressure regulator:

*3/4" NPT, up to 165,000 BTU/HR

*3/4" NPT, up to 320,000 BTU/HR

* 1" NPT, up to 500,000 BTU/HR

Cap, Manifold: left side right side

(Must specify when ordering.)

*S/S Cover, Manifold: left side right side

*Plate Shelf — 6" wide, S/S

*Casters — set of 4, 5" wheel, 6" height

*Flex Connector Kit — hose, disconnect and restraining device: *3' x 3/4" *4' x 3/4" *5' x 3/4"

*Security Options — i.e., prisons. Consult factory.

Exterior Dimensions: 36" wide x 36-5/8" deep. See drawing on reverse side for heights. For 42" depth add 6" to overall depth of range.



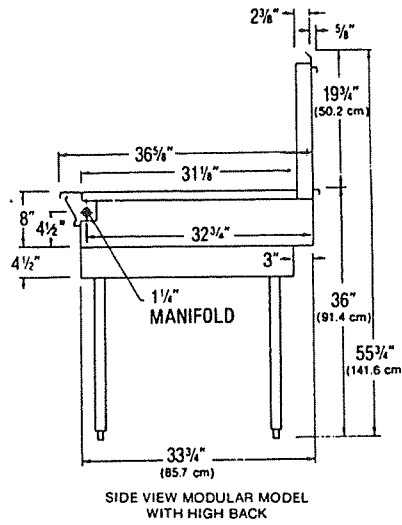
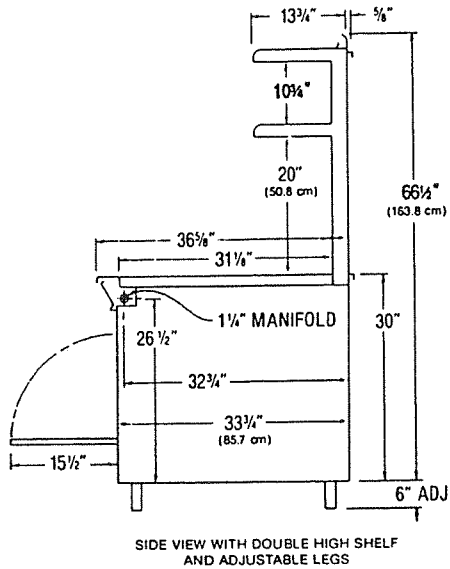
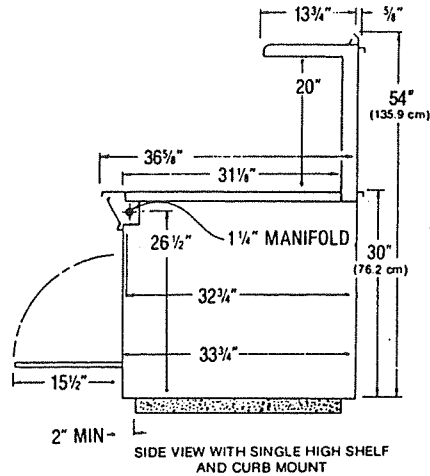
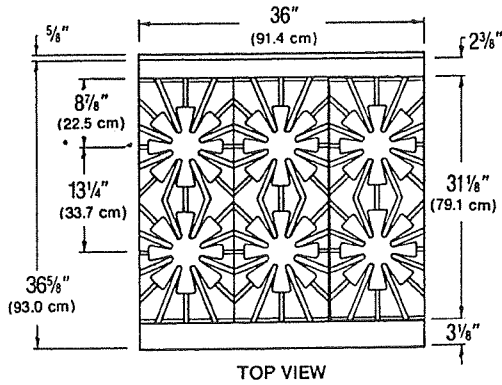

IMPORTANT:

Ranges must be installed in accordance with local codes or, in the absence of local codes, with the National Fuel Gas Code ANSI Z223.1. Compliance with codes is the responsibility of the Owner and Installer.

Adequate Ventilation System required. Refer to the National Fire Protection Association Standard No.96, "Vapor Removal from Cooking Equipment".

AGA Design Certified: in accordance with ANSI Z83.11 Gas Foodservice Equipment — Ranges. (Note: These appliances are intended for commercial use by professionally trained personnel. *NOT Intended For Household Use.*)

Minimum Clearances:	Combustible Construction	Noncombustible Construction
Back Wall:	2"	0"
Left & Right Side:	6"	0"
With 6" legs: suitable for installation on combustible floors.		
Without legs: For use only on noncombustible floors.		
*15" when installed with 30,000 BTU/HR burners.		
Counter models: For use on noncombustible counters only.		

TYPE OF GAS		Natural 4.0" WC	Propane 10" WC
Model	# burners	BTU/HR	BTU/HR
136-5	7	160,000	160,000
36-5	6	120,000	120,000
C36-5	6	120,000	120,000
M36-5	6	120,000	120,000

Add 10,000 BTU/HR for each 30,000 BTU/HR burner used. Deduct 5,000 BTU/HR for each -59 Open/Hot Top used.

GAS INLET SIZE (for all models):

1-1/4" front manifold with 1/2 union on each end provided for battery connection. Properly sized gas pressure regulator must be *Furnished By The Installer.*

Note: Specify type of gas Natural Propane
Specify elevation if installing above 2000 feet.

SHIPPING WEIGHT: *Class 77-1/2 **Class 85
136-5..... *536 lbs. C36-5.....**300 lbs.
36-5.....**352 lbs. M36-5.....**320 lbs.

ENTRY CLEARANCE: 30", all models, uncrated.

APPROX. CUBIC FT., (crated):

Cabinet base models... 27 Counter Models... 13

Design improvements may affect change in specification without notice.



THE MONTAGUE COMPANY
1830 Stearman Avenue, P.O. Box 4954
Hayward, CA 94540-4954
Telephone: 800/345-1830 (outside CA)

510/785-8822 (CA) FAX: 510/785-3342



Page 12
5246-9 1192

Appendix C
FREQUENCY DISTRIBUTION OF DATASET

FREQUENCY DISTRIBUTION OF DATASET

The frequency distribution of daily production energy consumption for the range cooktop is shown in Figure C-1. The frequency distribution of daily on-time for the range cooktop is shown in Figure C-2.

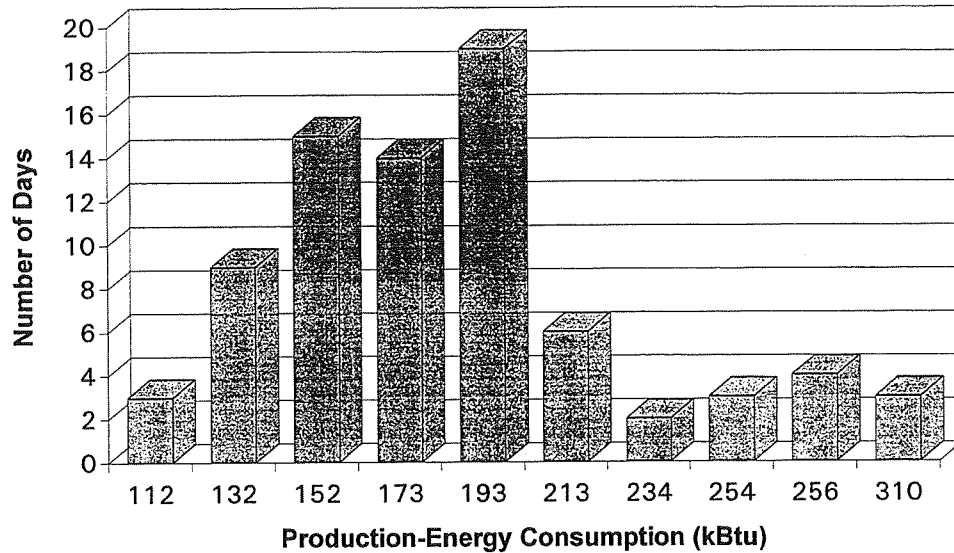

Figure C-1. Frequency of cooktop daily production energy consumption.

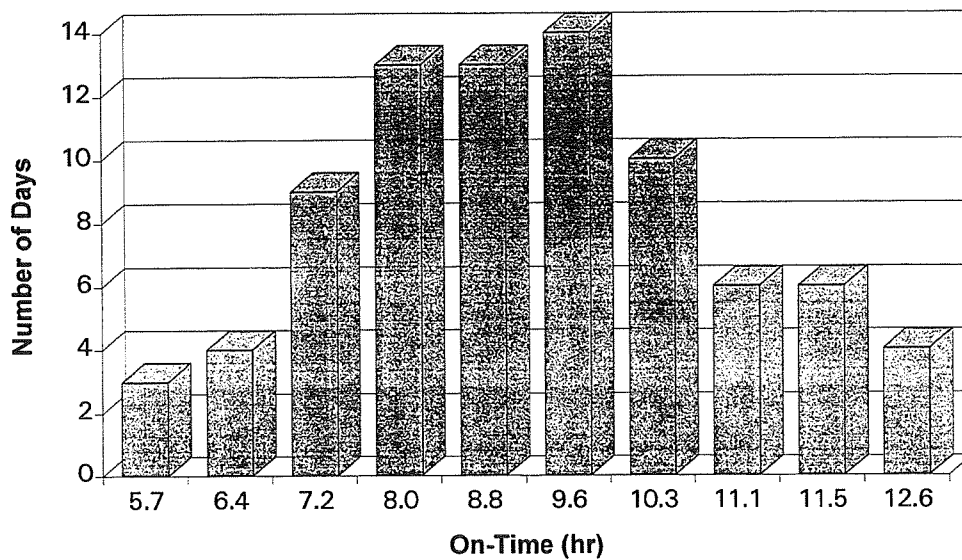

Figure C-2. Frequency of cooktop daily on-time.

Appendix D
PG&E ENERGY RATES



SCHEDULE G-NR1--GAS SALES TO SMALL NONRESIDENTIAL CORE CUSTOMERS

APPLICABILITY: Schedule G-NR1 is available to nonresidential Customers and applies to the combined sale and transportation of natural gas. To take service at Schedule G-NR1 rates, the uses of gas must be among those classified in PG&E's priority sequence as P1, P2A or P3A, and the Customer's average monthly use must not have exceeded 20,800 therms in those months during the last 12 months in which gas use exceeded 200 therms. (See Rule 14* for an exact description of these priorities.) Each March, service to all Customers under this schedule will be reviewed to determine continued applicability. Such determination will be based on natural gas use in the 12 billing months ending in the most recent calendar year.

TERRITORY: Schedule G-NR1 applies everywhere PG&E provides natural gas service.

RATES: The Customer will pay the following charges under this schedule:

	<u>Per Month</u>
Customer Charge	\$13.42(R)
Delivered Commodity Charge:	<u>Per Therm</u>
Summer Service	\$0.44812(I)
Winter Service	\$0.60496(I)

SEASONS: Winter Season begins November 1 and ends on March 31.
Summer Season begins April 1 and ends on October 31.

CURTAILMENT OF SERVICE: Service under this schedule may be curtailed. Details are provided in Rule 14.

TRANSPORTATION: If a Customer is taking service under this schedule in conjunction with any noncore service at the same premises, the Customer can qualify for gas transportation service. The transportation rate per therm will be the delivered commodity charge shown above less the core procurement rate. Customers who elect such transportation service will be required to sign a Natural Gas Service Agreement (Form No. 79-756). If there is a difference between actual deliveries and actual usage, such difference may be subject to the terms and conditions of Schedule G-BAL. Transportation volumes will be subject to a shrinkage allowance in accordance with Rule 21.

Or, transportation-only service is available in conjunction with Schedule G-CT -- Experimental Core Gas Transportation Service.

LIRA DISCOUNT FOR QUALIFIED NONPROFIT GROUP-LIVING FACILITIES: Nonprofit Group-Living Facilities which meet the eligibility criteria in Rule 19.2 are eligible for a Low-Income Ratepayer Assistance Discount under Schedule G-LIRA

Transportation customers will receive the LIRA discount only on the transportation services provided by PG&E.

* The rules referred to in this schedule are part of PG&E's gas tariff schedules. Copies are available at local offices.