



**Montague Model V136-5 Heavy-Duty
30,000 Btu/h Open Top Gas Range: Application
of ASTM Standard Test Method F 1521-94**

Report 5011.94.6

FSTC Manager: Don Fisher

Final Report, October 1995

Prepared by:

Richard Young

Cathy Cesio

Prepared for:

**Pacific Gas and Electric Company
Products and Services Department
444 Market Street, P.O. Box 770000
San Francisco, California 94177**

© 1994 by PG&E

**POLICY ON THE USE OF FOOD SERVICE TECHNOLOGY CENTER
TEST RESULTS AND OTHER RELATED INFORMATION**

- The FSTC is *strongly* committed to testing food service equipment using the best available scientific techniques and instrumentation.
- The FSTC is neutral as to fuel and energy source. It does not, in any way, encourage or promote the use of any fuel or energy source nor does it endorse any of the equipment tested at the FSTC.
- FSTC test results are made available to the general public through PG&E technical research reports and publications. All of these documents are protected under U.S. and international copyright laws.
- In the event that FSTC data is to be reported, quoted, or referred to in any way in publications, papers, brochures, advertising, or any other publicly available documents, the rules of copyright must be strictly followed, including written permission from PG&E *in advance* and proper attribution to PG&E and the Food Service Technology Center. In any such publication, sufficient text must be excerpted or quoted so as to give full and fair representation of findings as reported in the original documentation from FSTC.

PREFACE

Historically, performance testing of commercial cooking appliances has been conducted by food service equipment manufacturers and research organizations under controlled laboratory conditions. However, key decision makers in the food service industry have long seen a need to evaluate appliance performance under real-life conditions. Pacific Gas and Electric Company (PG&E) is providing this opportunity at its Food Service Technology Center (FSTC) in San Ramon, California.

The FSTC's production-test kitchen is a unique combination of a real food service operation and a testing laboratory at PG&E's corporate Learning Center dining facility. As a testing lab, it is equipped to measure the energy consumed by gas and electric cooking appliances as they are used for menu production. As a production kitchen, operated by the staff of a contract food service management company, the 162-seat dining facility provides cafeteria-style breakfast and lunch and table service dinner for the students and staff at PG&E's Learning Center.

The 6,700-square-foot appliance research laboratory complements the production-test kitchen by supporting the development and application of standard methods of tests for commercial food service equipment. The laboratory also provides an arena for identification and investigation of environmental issues related to food service facilities.

The Food Service Technology Center actively provides food service information to PG&E's customers through classes, demos and through PG&E's marketing representatives. Food Service Technology Center technical publications are available to PG&E customers as well as the general public.

ACKNOWLEDGMENTS

The state-of-the art Food Service Technology Center reflects PG&E's commitment to the hospitality industry. The goal of the research project is to provide PG&E's food service customers with information to help them evaluate technically innovative cooking appliances and make informed equipment purchases regarding advanced technologies and energy sources. The project was the result of many people and departments working together within PG&E and the overwhelming support of the commercial equipment manufacturers who loan the cooking appliances for testing. Specific appreciation is extended to the Montague Company for supplying PG&E with a gas range for testing at the Food Service Technology Center.

PG&E's Food Service Technology Center acknowledges the support of the project's National Advisory Group. Participating organizations from the research community include the Electric Power Research Institute (EPRI), the Gas Research Institute (GRI), the American Gas Association Laboratories (AGAL), and Underwriters Laboratories (UL). Representing end users are the National Restaurant Association, McDonald's Corporation, Darden Restaurants, Inc. (formerly General Mills Restaurants), Marriott International, and International Facility Management Association (IFMA).

EXECUTIVE SUMMARY

This study documents the performance of the Montague model V136-5 open top gas range top as determined by applying the American Society for Testing and Materials' (ASTM) *Standard Test Method for the Performance of Range Tops* (Designation F 1521).

Range top performance is characterized by temperature response and uniformity, pilot energy consumption, cooking energy efficiency, and production capacity. A summary of the cooking energy efficiency and production capacity test results is presented in Table ES-1.

Table ES-1
Cooking Energy Efficiency and Production Capacity Test Results.

Energy Input Rate Per Cooking Unit:	30,000 Btu/h
Pilot Energy Rate (Six Standing Pilots):	2,119 Btu/h
Average Temperature at Minimum Input:	293°F
Average Temperature at Maximum Input:	931°F
Cooking Energy Efficiency (without pot):	29.1%
Cooking Energy Efficiency (with pot):	30.8%
Production Capacity Per Cooking Unit:	68.9 lb/h

The Montague V136-5 is an excellent example of a heavy-duty six-burner range top with 30,000 Btu/h burners. These test results are useful not only in quantifying the performance of this range top but also as a benchmark against which other range top designs can be compared.

FSTC Manager

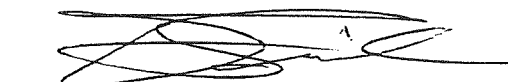

Donald R. Fisher

Technical Support
Supervisor



Peter W. Turnbull

CONTENTS

	Page
1 INTRODUCTION	1-1
BACKGROUND	1-1
OBJECTIVES	1-1
APPLIANCE DESCRIPTION AND OPERATION	1-1
TEST SETUP/INSTRUMENTATION	1-2
2 RESULTS	2-1
INPUT RATE TESTS	2-1
TEMPERATURE RESPONSE AND UNIFORMITY TESTS	2-1
COOKING PERFORMANCE TESTS	2-2
3 CONCLUSIONS	3-1
4 REFERENCES	4-1
Appendix A:	
GLOSSARY	
Appendix B:	
MANUFACTURER'S PRODUCT SPECIFICATIONS	
Appendix C:	
TEST RESULTS-DATA SHEETS	

FIGURES

Figure		Page
2-1	Temperature rise at maximum and minimum settings.....	2-1
2-2	Energy input rate vs. production rate	2-2

TABLES

Table		Page
1-1	Appliance Specifications.....	1-2
2-1	Cooking Energy Efficiency and Production Capacity Test Results	2-2

Section 1
INTRODUCTION

BACKGROUND

PG&E's Food Service Technology Center (FSTC) is developing uniform testing procedures (UTPs) to provide standard methods of testing commercial cooking appliances. We are submitting these procedures to the American Society for Testing and Materials (ASTM) for approval as national standard test methods. The data gathered in the application of these tests allow PG&E to educate end users about energy-efficient commercial cooking equipment. Terms used in this report are defined in the glossary (Appendix A). Support for the development and application of these test procedures comes from the Electric Power Research Institute (EPRI), the Gas Research Institute (GRI), and the National Restaurant Association.

OBJECTIVES

The *ASTM Standard Test Method for the Performance of Range Tops*¹ was applied to the Montague Model V136-5 gas range top configured with 30,000 Btu/h burners to evaluate its performance under tightly specified, repeatable conditions. The scope of this testing is as follows:

- Document the pilot energy consumption.
- Verify that the appliance is operating at the manufacturer's rated energy input.
- Characterize the minimum and maximum temperature rise and temperature uniformity.
- Document the cooking energy efficiency at half- and full-input rates.
- Determine the production capacity.

APPLIANCE DESCRIPTION AND OPERATION

The 180,000 Btu/h gas range cooktop includes three 12-inch open tops with six open burners, each rated at 30,000 Btu/h. Appliance specifications are given in Table 1-1. The manufacturer's specification sheet is in Appendix B and the data sheets generated during testing are in Appendix C.

Cooking utensils are supported by heavy-duty burner grates above the star burners. Each burner is manually controlled by a front-mounted control knob. Six standing pilots provide burner ignition.

Table 1-1
Appliance Specifications

Generic Appliance Type:	36" all-purpose open top range cooktop
Manufacturer:	The Montague Company
Model:	Legend V136-5
Rated Input:	180,000 Btu/h (range cooktop only)
Cooking unit:	30,000 Btu/h star burner
Dimensions:	36" wide by 36-5/8" deep by 34-1/2" high (to work surface)
Construction Material:	Steel with a stainless-steel front

TEST SETUP/INSTRUMENTATION

The range was installed on a tiled floor under a 4-foot-deep canopy hood that was 6 feet 6 inches above the floor. The hood operated at a nominal exhaust rate of 300 cfm per linear foot of hood. There was at least 6 inches of clearance between the vertical plane of the range top and the edge of the hood. All test apparatus were installed in accordance with Section 8 of the ASTM standard.¹

Gas consumption was measured with a calibrated gas meter with a 0.01-cubic-foot resolution. Cooking unit temperature rise and uniformity were measured with K-type thermocouples strain-gage-welded to a 12-inch diameter, 1/4-inch-thick steel plate. Water temperature was measured with T-type immersible thermocouple probes. The cooking container used for testing was an aluminum Wear Ever Model 4332, 12-in diameter, 14-qt, sauce pot weighing 4.53 lb, with an aluminum lid weighing 1.14 lb. Each test load consisted of 20 lb of water. All data were logged using a Fluke Helios data logger and recorded on a PC. The testing software was developed by the FSTC using Microsoft® Visual Basic™ Professional Version.

Section 2
RESULTS

INPUT RATE TESTS

The input gas pressure, air shutters, and pilots were adjusted as suggested in the manufacturer's installation manual. Input rate tests were performed on the six cooking units and the pilots in accordance with the ASTM test method. The energy input rates for the six individual cooking units varied an average of 2.7% from the manufacturer's 30,000 Btu/h rating. The input rate for all six burners operating at once was 4.6% lower than the 180,000 Btu/h nameplate of the range top. The input rate for the six pilots was 2,119 Btu/h, or 353 Btu/h per pilot.

TEMPERATURE RESPONSE AND UNIFORMITY TESTS

FSTC researchers attached 17 thermocouples to a 1/4-inch-thick, 12-inch-diameter carbon steel plate, as detailed in section 10.4 of the ASTM test method. The cooking unit was turned on to the minimum control setting and time, temperature, and energy were recorded over the next hour. Input rate at the minimum setting was 5,468 Btu/h. Based on the 17 temperature measurement points, the average plate temperature at the end of the hour was 293°F, with a standard deviation of 17°F. The test was repeated with the cooking unit controls at the maximum setting (an input rate of 31,595 Btu/h) and the average plate temperature at the end of the hour was 931°F, with a standard deviation of 68°F. The average temperature rise for each test is plotted in Figure 2-1.

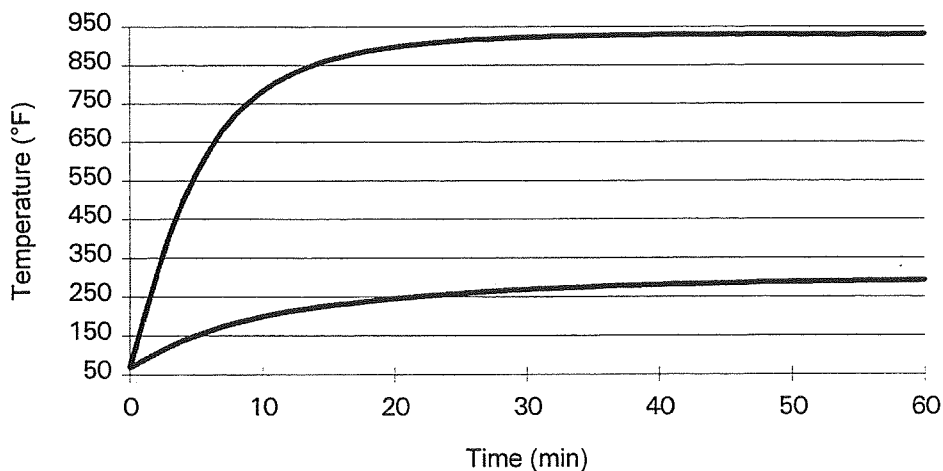

Figure 2-1. Temperature rise at maximum and minimum settings.

COOKING PERFORMANCE TESTS

Table 2-1 presents the results of the cooking energy efficiency and production capacity tests for the range top. Three test runs were performed at half-input rate and three were performed at full-input rate in accordance with section 10.5 of the ASTM test method. The FSTC is planning to submit to ASTM a revised *Standard Test Methods for the Performance of Range Tops* which will include the weight of the cooking container in the energy efficiency equation. In anticipation of this revision, the cooking energy efficiency data in Table 2-1 reports the efficiency with and without the weight of the cooking container. The production capacity per cooking unit remains the same with or without the cooking container because only the weight of the water is considered in production.

Table 2-1
Cooking Energy Efficiency and Production Capacity Test Results

Cooking Energy Efficiency	without pot	with pot	uncertainty
Half-Energy Input Rate:	27.6%	29.2%	2.9%
Full-Energy Input Rate:	29.1%	30.8%	4.3%
Production Capacity Per Cooking Unit			
Half-Energy Input Rate:	33.8 lb/h		
Full-Energy Input Rate:	68.9 lb/h		

In Figure 2-2, production rate is plotted against input rate. Knowing the energy input rate required to achieve a desired production rate is helpful in estimating the cost of operation.

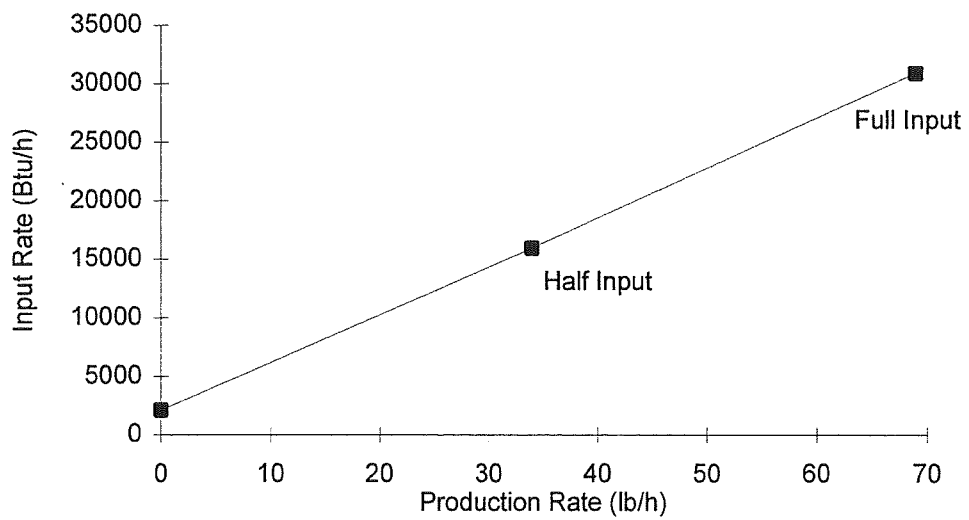

Figure 2-2. Energy input rate vs. production rate.

Section 3
CONCLUSIONS

Range top energy use and performance were accurately tested and quantified during application of the uniform test procedure for range tops. Temperature response and uniformity test results help to characterize the heat transfer of the 30,000 Btu/h star burner. At full input, the burner delivered enough heat to the test plate to raise the average temperature to over 850°F within 15 minutes, reaching a final average temperature of 931°F. At minimum input, the average temperature was 293°F. Heat produced by the burner at both the minimum and maximum input rates was evenly distributed over the surface of the test plate, with slight increases at the center of the plate and over the pilots.

The cooking energy efficiency at the half-input rate was 27.6% rising slightly to 29.1% at the full-input rate. The revised cooking energy efficiency, which includes the weight of the cooking container, is 29.2% at half-input rate and 30.8% at full-input rate. Based on a temperature rise from 70° to 200°F, the production rate for the cooking unit tested was 33.8 lb/hr at the half-input rate and 68.9 lb/hr at the full-input rate.

The Food Service Technology Center also applied the *ASTM Standard Test Method for the Performance of Range Tops* to the Montague model V136-5, heavy-duty, 20,000 Btu/h burner, open top gas range.² The cooking energy efficiency for the 30,000 Btu/h cooking unit (at full-input and including the cooking container) is 30.8%, which is almost the same as the 31.7% efficiency of the 20,000 Btu/h unit. However, the production capacity of the 30,000 Btu/h cooking unit was significantly higher (68.9 lb/h) than the production capacity of the 20,000 Btu/h unit (50.5 lb/h) demonstrating that the 30,000 Btu/h cooking unit can increase production without compromising energy efficiency.

Section 4

REFERENCES

1. American Society for Testing and Materials. ASTM F 1521-94. *Standard Test Methods for the Performance of Range Tops*. In *Annual Book of ASTM Standards*. Philadelphia: American Society for Testing and Materials. This test method can be purchased from the American Society for Testing and Materials, 1916 Race Street, Philadelphia, Pennsylvania 19103.
2. Pacific Gas and Electric Company. 1995. Montague Model V136-5 Heavy-Duty 20,000 Btu/h Open Top Gas Range: Application of *ASTM Standard Test Method F 1521-94*. Report 5011.94.6 prepared for PG&E Products and Services, San Francisco, California.

Appendix A
GLOSSARY

GLOSSARY

Cooking Energy

Energy consumed by the range top as it is used to cook at half- and full-energy input rates.

Cooking Energy Efficiency

The quantity of energy input to the food, expressed as a percentage of the quantity of energy input to the range top during the half- and full-energy input rate cooking energy efficiency tests.

Energy Input Rate (kW or kBtu/h)

Energy Consumption Rate
Energy Rate

The rate (Btu/h or kW) at which an appliance will consume energy.

Range Top

A device for cooking food by direct or indirect heat transfer from one or more cooking units to one or more cooking containers.

Heating Value

Heating Content

The quantity of heat (energy) generated by the combustion of the fuel. For natural gas, this quantity varies depending on the constituents of the gas.

Pilot Energy Consumption (kBtu)

Pilot Energy Use
Standing or Constant Pilot Energy Consumption
Standing or Constant Pilot Energy Use

The rate of energy consumption by the standing or constant pilot(s) while the appliance is not being operated (i.e., when the thermostats or control knobs have been turned off).

Production Capacity

The production rate (lb/h) of the range top as it is used to cook at half- and full-energy input rates.

Test Method

A definitive procedure for the identification, measurement, and evaluation of one or more qualities, characteristics, or properties of a material, product, system, or service that produces a test result.

Temperature Response

The temperature rise measured on the surface of a steel plate during the test period in accordance with the heat-up temperature-response test.

Temperature Uniformity

The comparison of individual temperatures measured on the surface of a steel plate at the end of the test period in accordance with the heat-up temperature-response test.

Appendix B
MANUFACTURER'S PRODUCT SPECIFICATIONS

MONTAGUE **LEGEND** Gas Heavy Duty Range — 136-5

ITEM NO.:

JOB I.D. NO.:

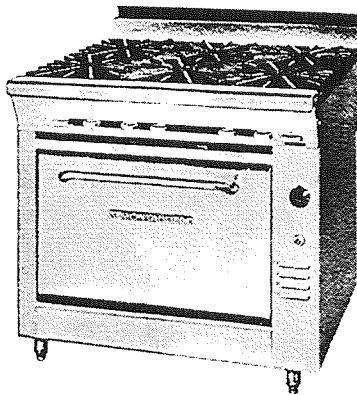

Model 136-5



Model 36-5



Model M36-5

Model Variations:

- 136-5** — Oven model with 6" legs.
- 36-5** — Cabinet model with 6" legs.
- M36-5** — Countertop model with 28" high modular stand with S/S tubular legs.
- C36-5** — Counter model without legs.
 - *4" legs (Optional. *Must be factory installed.*)

Open Tops: Three 12" wide x 31" deep heavily ribbed cast iron grates. Six each open burners. Each Star burner has individually raised ports to help prevent clogging from spillovers and for better combustion. Burners are rated at 20,000 BTU/HR each, with automatic constant burning pilots. Drip pan under open burners.

Options, *(extra cost):

- 59 top(s), rated @ 15,000 BTU/HR each, 12" wide x 31" deep cast iron top with heavily ribbed open burner grate across front and Solid Hot Top section across rear. Located:
 - 1, right 1, center 1, left
- *Ribbon Grate, cast iron. (In-lieu-of 12" open burner grate.)
 - Note: For use with 20,000 BTU/HR burners. Located:
 - *1, right *1, center *1, left
- *30,000 BTU/HR Star open burner for use with Natural gas:
 - *3, front *3, back *6, front and back

Oven Interior: The front venting oven is 26" wide x 28" deep x 15" high. Standard interior finish is porcelainized steel.

Options, *(extra cost):

- *Catalytic continuous cleaning interior (CCL)
- *Cast iron oven bottom

The 3-position rack guides and oven bottom are removable for major cleaning. The oven is heated by a cast iron burner rated at 40,000 BTU/HR. The oven cavity is completely encased in high density fiberglass insulation maximizing heat retention. One rack with bright nickel finish is furnished.

Oven Controls: Includes manual burner valve, heavy duty throttling type thermostat, 100% safety pilot and automatic

lighting. Controls are located in an insulated and vented compartment for longer life. Thermostat located on front right side. Thermostat dial has a temperature range from low to 500°F (260°C).

Oven Doors: Weight counterbalanced without the use of springs. One piece offset tubular-type handle is used.

Finish: Satin finish stainless steel front, including 4" flue riser. Remaining exterior black. All painted surfaces have electrolytic zinc undercoating for corrosion protection and longer life. Additional S/S finish available, *(extra cost):

- *S/S left side *S/S right side *S/S back panel
- *S/S lower shelves for cabinet base, (2 ea. required)

NOTE: Black finish with S/S trim available.

Options, *(extra cost):

- | | S/S front | Black |
|---|--------------------------|--------------------------|
| <input type="checkbox"/> *18" High Back: | <input type="checkbox"/> | <input type="checkbox"/> |
| <input type="checkbox"/> *Single High Shelf: | <input type="checkbox"/> | <input type="checkbox"/> |
| <input type="checkbox"/> *Double High Shelf: | <input type="checkbox"/> | <input type="checkbox"/> |
| <input type="checkbox"/> *Doors for Cabinet Base: | <input type="checkbox"/> | <input type="checkbox"/> |
| <input type="checkbox"/> *Extra Oven Racks | | |
| <input type="checkbox"/> *42" Range Depth, suffix -40 | | |
| <input type="checkbox"/> *Left Rear Manifold with pressure regulator: | | |
| <input type="checkbox"/> *3/4" NPT, up to 165,000 BTU/HR | | |
| <input type="checkbox"/> *3/4" NPT, up to 320,000 BTU/HR | | |
| <input type="checkbox"/> * 1" NPT, up to 500,000 BTU/HR | | |
| <input type="checkbox"/> Cap, Manifold: <input type="checkbox"/> left side <input type="checkbox"/> right side | | |
| (Must specify when ordering.) | | |
| <input type="checkbox"/> *S/S Cover, Manifold: <input type="checkbox"/> left side <input type="checkbox"/> right side | | |
| <input type="checkbox"/> *Plate Shelf — 6" wide, S/S | | |
| <input type="checkbox"/> *Casters — set of 4, 5" wheel, 6" height | | |
| <input type="checkbox"/> *Flex Connector Kit — hose, disconnect and restraining device: <input type="checkbox"/> *3' x 3/4" <input type="checkbox"/> *4' x 3/4" <input type="checkbox"/> *5' x 3/4" | | |
| <input type="checkbox"/> *Security Options — i.e., prisons. Consult factory. | | |

Exterior Dimensions: 36" wide x 36-5/8" deep. See drawing on reverse side for heights. For 42" depth add 6" to overall depth of range.



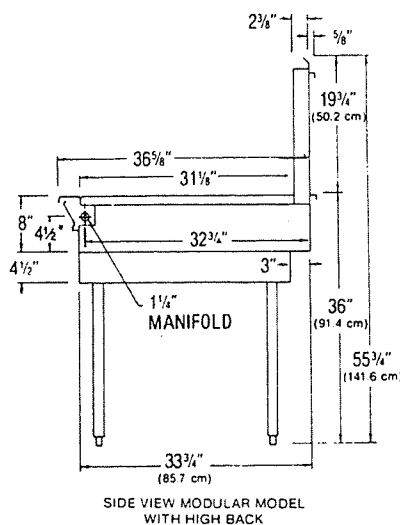
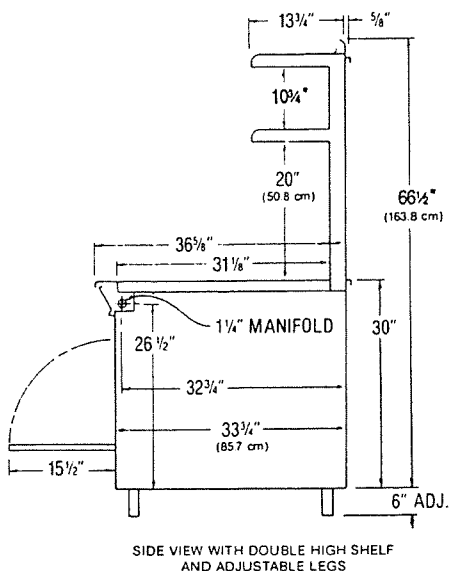
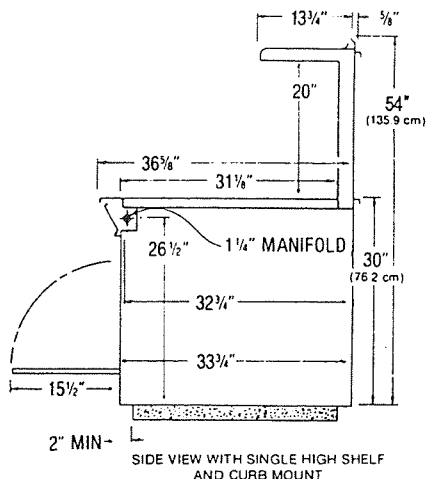
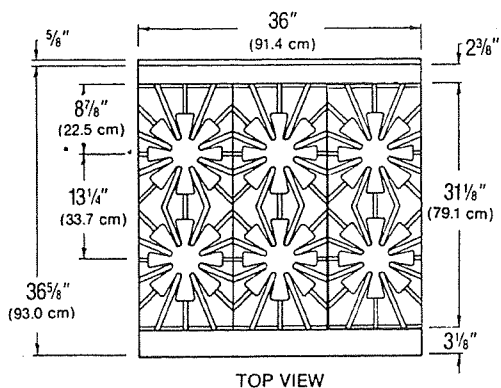

IMPORTANT:

Ranges must be installed in accordance with local codes or, in the absence of local codes, with the National Fuel Gas Code ANSI Z223.1. Compliance with codes is the responsibility of the Owner and Installer.

Adequate Ventilation System required. Refer to the National Fire Protection Association Standard No.96, "Vapor Removal from Cooking Equipment".

AGA Design Certified: in accordance with ANSI Z83.11 Gas Foodservice Equipment — Ranges. (Note: These appliances are intended for commercial use by professionally trained personnel. *NOT Intended For Household Use.*)

Minimum Clearances:	Combustible Construction	Noncombustible Construction
Back Wall:	2"	0"
Left & Right Side:	*6"	0"
With 6" legs: suitable for installation on combustible floors.		
Without legs: For use only on noncombustible floors.		
*15" when installed with 30,000 BTU/HR burners.		
Counter models: For use on noncombustible counters only.		

TYPE OF GAS		Natural 4.0" WC	Propane 10" WC
Model	# burners	BTU/HR	BTU/HR
136-5	7	160,000	160,000
36-5	6	120,000	120,000
C36-5	6	120,000	120,000
M36-5	6	120,000	120,000

Add 10,000 BTU/HR for each 30,000 BTU/HR burner used. Deduct 5,000 BTU/HR for each -59 Open/Hot Top used.

GAS INLET SIZE (for all models):

1-1/4" front manifold with 1/2 union on each end provided for battery connection. Properly sized gas pressure regulator must be *Furnished By The Installer.*

Note: Specify type of gas Natural Propane
Specify elevation if installing above 2000 feet.

SHIPPING WEIGHT: *Class 77-1/2 **Class 85
136-5..... *536 lbs. C36-5.....**300 lbs.
36-5.....**352 lbs. M36-5.....**320 lbs.

ENTRY CLEARANCE: 30", all models, uncrated.

APPROX. CUBIC FT., (crated):

Cabinet base models... 27 Counter Models... 13

Montague's sole commitment to quality/product improvement can cause specification and design changes without prior notice.



THE MONTAGUE COMPANY

1830 Stearman Avenue, P.O. Box 4954
Hayward, CA 94540-4954
Telephone: 800/345-1830 (outside CA)

510/785-8822 (CA) FAX: 510/785-3342



Page 12
5246-9 1192

MONTAGUE **LEGEND** Gas Convection Oven Range — V136



ITEM NO.:

JOB I.D. NO.:

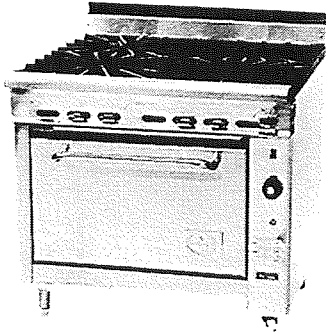

Model V136-5A



Control Panel

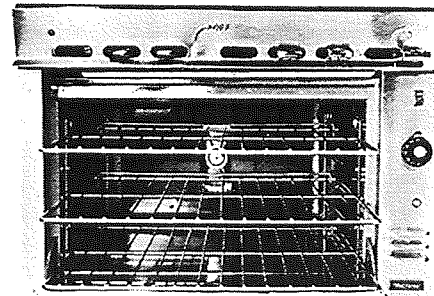

Interior Oven View

General: V136 Series offers a choice of over 20 heavy duty cooking tops in different combinations of Fry Tops, Hot Tops and Open Tops with a Vectaire convection oven below. The convection oven utilizes an indirect heating system. The products of combustion are completely isolated from the baking products. Combustion takes place in a closed chamber and heat is uniformly transferred through side walls, top and bottom of oven cavity. Convection oven cooking reduces temperatures at least 25% from those given in standard recipes. V136 convection oven ranges provide the most economical energy saving use of floor space available.

Range Tops: *Fry Tops* are available in 12", 18", 24" or 36" widths x 28" deep (34" deep for -40 models) x 3/4" thick (standard). All heated by 1, 2, 3 or 4 burners respectively, rated @ 15,000 BTU/HR each. Thermostatically controlled and -40 Fry Top burners rated @ 20,000 BTU/HR each. **Solid Hot Tops** are available in various multiples, either 12" wide or 18" wide x 31" deep, each section front fired with one burner rated @ 18,500 BTU/HR or 35,000 BTU/HR respectively. The 12" wide or 18" wide Even-Heat Hot Tops may be substituted with 1 or 2 burners respectively rated @ 20,000 BTU/HR each. **Ring and Cover Hot Tops** are available, each 18" wide x 31" deep. Each section front fired with one Banjo type burner rated @ 35,000 BTU/HR. **Open Tops** are available in various multiples, either 12" wide or 18" wide x 31" deep cast iron sections with heavily ribbed grates. Each section provided with 2 Star burners rated @ 20,000 BTU/HR each.

Options, *(extra cost):

- 59 top(s), rated @ 15,000 BTU/HR each, 12" wide x 31" deep cast iron top with heavily ribbed open burner grate across front and Solid Hot Top section across rear. Located:
 - 1, right 1, center 1, left
- *Ribbon Grate, cast iron. (In-lieu-of 12" open burner grate.)
Note: For use with 20,000 BTU/HR burners. Located:
 - *1, right *1, center *1, left
- *30,000 BTU/HR Star open burner for use with Natural gas:
 - *front *back *front and back

Oven Interior: The "muffled" oven is 26-5/8" wide x 22-1/4" deep x 15" high. Interior finish is porcelainized 16 gauge steel. Removable 5-position, bright nickel rack guides are provided. The oven is heated by a cast iron burner rated @ 45,000 BTU/HR. The oven cavity is completely encased in high density fiberglass insulation maximizing heat retention. Three oven racks with bright nickel finish are furnished.

Oven Controls: Controls are mounted on the right side in an insulated and vented compartment for longer life. Controls include: heavy duty modulating thermostat (200°F—500°F), three position rocker switch with automatic FAN, OFF, COOL DOWN modes, door switch to automatically shut fan off when door opens, and 100% automatic ignition safety pilot. The controls are located out of the heat zone and easily accessible for maintenance.

Oven Doors: Weight counterbalanced without the use of springs. One piece offset tubular-type handle is used.

Oven Motor: 1/4 Hp, 115 VAC, 60 Hz, 4.4 amps, 1PH, with 6 ft., 3-wire cord with plug. Self-lubricating, sealed ball bearing type requires no lubricating for life. Motor has thermal overload protection and is serviceable from the front of oven through oven chamber.

Finish: Satin finish stainless steel front, including 4" flue riser. Remaining exterior black. All painted surfaces have electrolytic zinc undercoating for corrosion protection and longer life. Additional S/S finish available, *(extra cost):
 *S/S left side *S/S right side *S/S back panel
 NOTE: Black finish with stainless steel trim available.



Options, *(extra cost):

- | | S/S front | Black |
|---|--------------------------|--------------------------|
| <input type="checkbox"/> *18" High Back: | <input type="checkbox"/> | <input type="checkbox"/> |
| <input type="checkbox"/> *Single High Shelf: | <input type="checkbox"/> | <input type="checkbox"/> |
| <input type="checkbox"/> *Double High Shelf: | <input type="checkbox"/> | <input type="checkbox"/> |
| <input type="checkbox"/> *Extra Oven Racks | | |
| <input type="checkbox"/> *42" Range Depth, suffix -40 | | |
| <input type="checkbox"/> *Left Rear Manifold with pressure regulator: | | |
| <input type="checkbox"/> *3/4" NPT up to 165,000 BTU/HR | | |
| <input type="checkbox"/> *3/4" NPT up to 320,000 BTU/HR | | |
| <input type="checkbox"/> * 1" NPT up to 500,000 BTU/HR | | |
| <input type="checkbox"/> Cap, Manifold: <input type="checkbox"/> left side <input type="checkbox"/> right side | | |
| (Must specify when ordering.) | | |
| <input type="checkbox"/> *S/S Cover, Manifold: <input type="checkbox"/> left side <input type="checkbox"/> right side | | |
| <input type="checkbox"/> *Extended Fry Top over more than one range, up to 72" wide | | |
| <input type="checkbox"/> *Plate Shelf — 6" wide, S/S | | |
| <input type="checkbox"/> *Casters — set of 4, 5" wheel, 6" height | | |
| <input type="checkbox"/> *Flex Connector Kit — hose, disconnect and restraining device: <input type="checkbox"/> *3' x 3/4" <input type="checkbox"/> *4' x 3/4" <input type="checkbox"/> *5' x 3/4" | | |
| <input type="checkbox"/> *Security Options — i.e., prisons. Consult factory. | | |

Exterior Dimensions: 36" wide x 36-5/8" deep. See drawing on reverse side for heights. For 42" depth add 6" to overall depth of range.

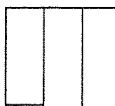
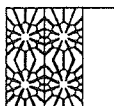
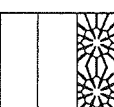
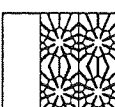
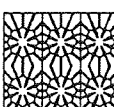
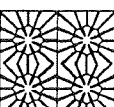
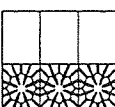
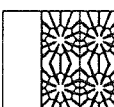
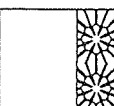

MODELS, BTUS & SHIPPING WEIGHTS

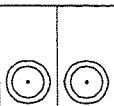
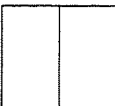
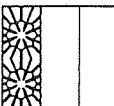
 V136-0 108,500 BTU/HR 768 Lbs. One 24" Fry Top One 12" Hot Top	 V136-1 97,000 BTU/HR 735 Lbs. One 12" Fry Top Two 12" Hot Tops	 V136-2 143,500 BTU/HR 631 Lbs. Two 12" Open Tops One 12" Hot Top
 V136-3 122,000 BTU/HR 669 Lbs. Two 12" Hot Tops One 12" Open Top	 V136-4 143,500 BTU/HR 619 Lbs. One 12" Hot Top Two 12" Open Tops	 V136-5 165,000 BTU/HR 610 Lbs. Three 12" Open Tops
 V136-5A 125,000 BTU/HR 585 Lbs. Two 18" Open Tops	 V136-559 150,000 BTU/HR 625 Lbs. Three 12" Combination Open Top / Hot Tops	 V136-6 140,000 BTU/HR 659 Lbs. One 12" Fry Top Two 12" Open Tops
 V136-7 130,000 BTU/HR 685 Lbs. One 24" Fry Top One 12" Open Top	 V136-8 105,000 BTU/HR 722 Lbs. One 36" Fry Top	 V136-9 100,500 BTU/HR 642 Lbs. Three 12" Hot Tops
 V136-9A 115,000 BTU/HR 681 Lbs. Two 18" Hot Tops with Ring & Cover	 V136-9ASE 125,000 BTU/HR 613 Lbs. Two 18" Hot Tops	 V136-10 122,000 BTU/HR 636 Lbs. One 12" Open Top Two 12" Hot Tops

 Optional ribbon grate — replaces 12" Open Top.

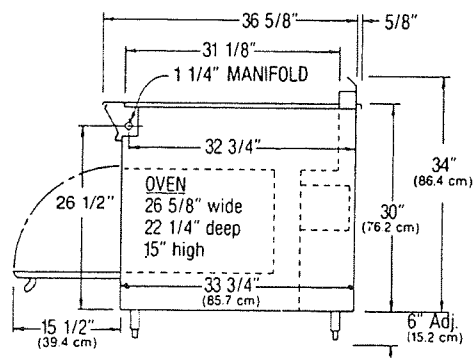
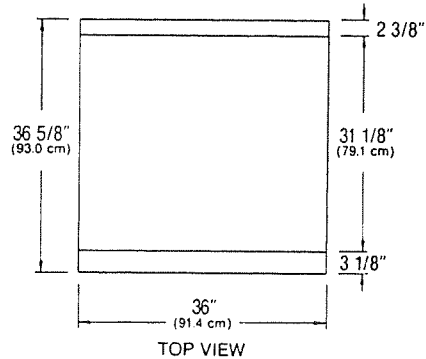

IMPORTANT:

Ranges must be installed in accordance with local codes or, in the absence of local codes, with the National Fuel Gas Code ANSI Z223.1. Compliance with codes is the responsibility of the Owner and Installer.

Adequate Ventilation System required. Refer to the National Fire Protection Association Standard No.96, "Vapor Removal from Cooking Equipment".

AGA Design Certified: in accordance with ANSI Z83.11 Gas Foodservice Equipment — Ranges. Note: These appliances are intended for commercial use by professionally trained personnel. *NOT Intended For Household Use.*

Minimum Clearances:	Combustible Construction	Noncombustible Construction
Back Wall:	2"	2"
Left & Right Side:	*6"	0"
With 6" legs: suitable for installation on combustible floors.		
Without legs: For use only on noncombustible floors.		
*15" when installed with 30,000 BTU/HR burners.		
Cannot curb mount convection ovens.		

TYPE OF GAS	Natural 4.0" WC	Propane 10" WC
Model # burners	BTU/HR	BTU/HR
V136 (see "Models, BTUs & Shipping Weights")		
For 42" depth thermostatically controlled Fry Top, add 5,000 BTU/HR per burner. Add 10,000 BTU/HR for each 30,000 BTU/HR burner used. Deduct 5,000 BTU/HR for each -59 Open/Hot Top used. Add 1,500 BTU/HR per Hot Top for Even Heat option — suffix E.		

GAS INLET SIZE (for all models):
1-1/4" front manifold with 1/2" union on each end provided for battery connection. Properly sized gas pressure regulator must be *Furnished By The Installer.*

Note: Specify type of gas Natural Propane
Specify elevation if installing above 2000 feet.

ENTRY CLEARANCE: 30", all models, uncrated.

APPROX. CUBIC FT., (crated):
Ranges w/ Fry Top... 32 Ranges w/out Fry Top... 27

Montague's sole commitment to quality/product improvement can cause specification and design changes without prior notice.



THE MONTAGUE COMPANY

1830 Stearman Avenue, P.O. Box 4954
Hayward, CA 94540-4954
Telephone: 800/345-1830 (outside CA) 510/785-8822 (CA) FAX: 510/785-3342



Appendix C
TEST RESULTS-DATA SHEETS

Data Sheet for Range Top UTP

company: Montague

model: V136 - 5

fuel: gas

notes: 6 open burners - 30,000 Btu/h each

pilot energy: 2119 Btu/h

energy input rate: test sequence was rr,rf,cr,cf,lr,lf,all

	Btu/h	nameplate	% diff
unit 1	<u>31911</u>	unit 1 <u>30000</u>	6.4
unit 2	<u>31091</u>	unit 2 <u>30000</u>	3.6
unit 3	<u>30271</u>	unit 3 <u>30000</u>	0.9
unit 4	<u>31091</u>	unit 4 <u>30000</u>	3.6
unit 5	<u>30271</u>	unit 5 <u>30000</u>	0.9
unit 6	<u>30271</u>	unit 6 <u>30000</u>	0.9
unit 7	<u>na</u>	unit 7 <u>na</u>	
unit 8	<u>na</u>	unit 8 <u>na</u>	
all units	<u>171721</u>	all units <u>180000</u>	4.6

17 temperatures on plate at end of 1 hour of operation at minimum control setting:

1	<u>316</u>	7	<u>290</u>	13	<u>282</u>
2	<u>305</u>	8	<u>289</u>	14	<u>272</u>
3	<u>315</u>	9	<u>294</u>	15	<u>267</u>
4	<u>311</u>	10	<u>285</u>	16	<u>266</u>
5	<u>303</u>	11	<u>319</u>	17	<u>273</u>
6	<u>295</u>	12	<u>296</u>	input rate: <u>5468</u> Btu/h	

average plate temperature (average of 17 temperatures): 293 °F

17 temperatures on plate at end of 1 hour of operation at maximum control setting:

1	<u>998</u>	7	<u>968</u>	13	<u>878</u>
2	<u>995</u>	8	<u>965</u>	14	<u>867</u>
3	<u>997</u>	9	<u>974</u>	15	<u>834</u>
4	<u>1004</u>	10	<u>875</u>	16	<u>846</u>
5	<u>1022</u>	11	<u>869</u>	17	<u>857</u>
6	<u>995</u>	12	<u>884</u>	input rate: <u>31595</u> Btu/h	

average plate temperature (average of 17 temperatures): 931 °F

company: Montague
fuel: gas

page: 2
model: V136 - 5
notes: 6 open burners - 30,000 Btu/h each

Temperature Plots:

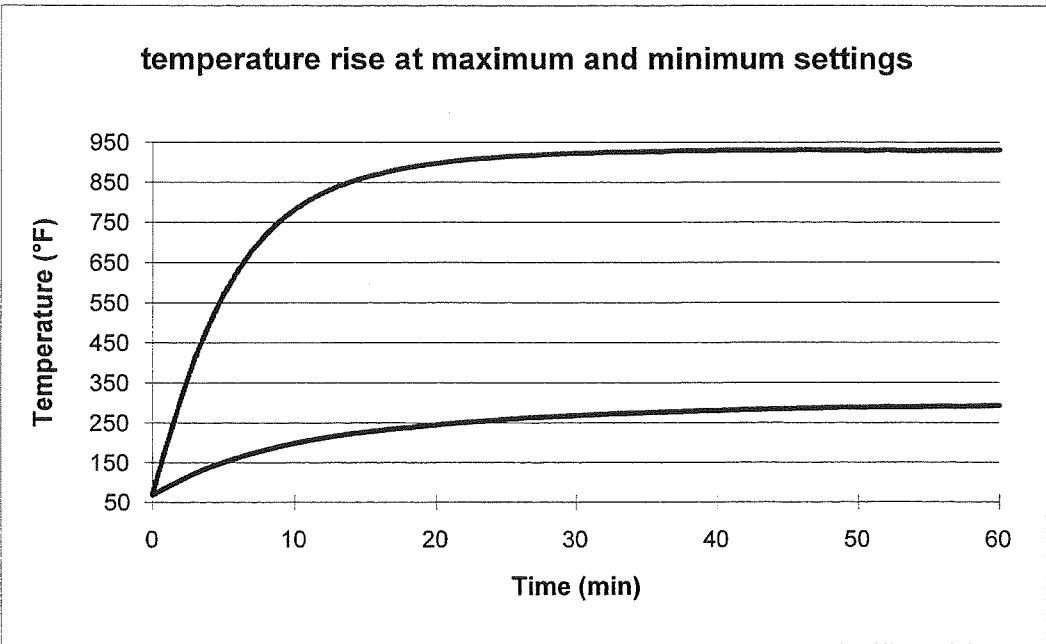

company: Montague
 fuel: gas

page: 3
 model: V136 - 5
 notes: 6 open burners - 30,000 Btu/h each

montague 30

	half input				
run	1	2	3	4	average
pot wt	5.67	5.67	5.67	5.67	
H2O wt	20	20	20	20	
delta t	129.6	131.0	130.6	130.7	
time	35.0	36.0	35.0	36.0	
lb/h	34.3	33.3	34.3	33.3	33.8
gas cf	0.99	0.99	0.99	0.99	
cu ft	9.1	9.5	9.2	9.5	
hv	1022.9	1022.9	1022.9	1022.9	
Btu	9215.3	9620.4	9316.6	9620.4	
Btu/h	15797.7	16034.0	15971.3	16034.0	15959.2
sens pot	147.0	148.5	148.1	148.2	
sens H2O	2592.0	2619.9	2611.8	2614.1	
eff w/pot	29.7	28.8	29.6	28.7	29.2
eff w/o pot	28.1	27.2	28.0	27.2	27.6
% uncertainty					2.9

	full input			
run	1	2	3	average
pot wt	5.67	5.67	5.67	
H2O wt	20	20	20	
delta t	130.8	130.2	131.4	
time	17.3	17.8	17.3	
lb/h	69.6	67.6	69.6	68.9
gas cf	0.99	0.99	0.99	
cu ft	8.8	9	8.8	
hv	1022.9	1022.9	1022.9	
Btu	8911.5	9114.0	8911.5	
Btu/h	30996.5	30808.0	30996.5	30933.7
sens pot	148.3	147.6	149.0	
sens H2O	2615.3	2603.1	2628.1	
eff w/pot	31.0	30.2	31.2	30.8
eff w/o pot	29.3	28.6	29.5	29.1
% uncertainty				4.3

