



**Garland® Air Deck™ Model G56PB
Deck Oven Performance Test**

Application of ASTM Standard
Test Method F 1965-99

FSTC Report 5011.99.76

**Food Service Technology Center Manager: Don Fisher
Final Report, October 1999**

Prepared by:

**Greg Sorensen
Richard Young**

**Fisher-Nickel, Inc.
Danville, CA 94526**

Prepared for:

**Peter Turnbull
Pacific Gas and Electric Company
Customer Energy Management
123 Mission Street, P.O. Box 770000
San Francisco, California 94177**

© 1999 by Pacific Gas and Electric Company. All rights reserved.

Acknowledgments

The establishment of a Food Service Technology Center reflects Pacific Gas and Electric Company's commitment to the food service industry. The goal of the research project is to provide Pacific Gas and Electric Company's customers with information to help them evaluate technically innovative food service equipment and systems, and make informed equipment purchases regarding advanced technologies and energy sources. The project was the result of many people and departments working together within Pacific Gas and Electric Company and the overwhelming support of the commercial equipment manufacturers who supplied the cooking appliances for testing.

Pacific Gas and Electric Company's Food Service Technology Center is supported by the National Advisory Group, which includes:

California Café Restaurant Corporation
California Energy Commission (CEC)
California Restaurant Association (CRA)
Darden Restaurants, Inc.
Electric Power Research Institute (EPRI)
Gas Appliance Manufacturers Association (GAMA)
Gas Research Institute (GRI)
International Facility Management Association (IFMA)
McDonald's Corporation
National Restaurant Association
Round Table Pizza
Safeway, Inc.
Underwriters Laboratories (UL)
University of California, Berkeley (UC Berkeley)
University of California, Riverside (CE-CERT)

Specific appreciation is extended to Garland Commercial Industries, Inc. for supplying the Food Service Technology Center with the Air Deck Model G56PB deck oven for controlled testing in the appliance laboratory.

Policy on the Use of Food Service Technology Center Test Results and Other Related Information

- The Pacific Gas and Electric Company's Food Service Technology Center (FSTC) is *strongly* committed to testing food service equipment using the best available scientific techniques and instrumentation.
- The FSTC does not endorse equipment tested at the facility; test results reported herein should not be construed or interpreted as an endorsement of the equipment tested.
- The FSTC is neutral as to fuel and energy source. It does not, in any way, encourage or promote the use of any fuel or energy source.
- FSTC test results are made available to the general public through both Pacific Gas and Electric Company technical research reports and publications and are protected under U.S. and international copyright laws.
- In the event that FSTC data are to be reported, quoted, or referred to in any way in publications, papers, brochures, advertising, or any other publicly available documents, the rules of copyright must be strictly followed, including written permission from Pacific Gas and Electric Company *in advance* and proper attribution to Pacific Gas and Electric Company and the Food Service Technology Center. In any such publication, sufficient text must be excerpted or quoted so as to give full and fair representation of findings as reported in the original documentation from FSTC.

Legal Notice

This report was prepared by Pacific Gas and Electric Company for exclusive use by its employees and agents. Neither Pacific Gas and Electric Company nor any of its employees:

- (1) makes any written or oral warranty, expressed or implied, including, but not limited to those concerning merchantability or fitness for a particular purpose;
- (2) assumes any legal liability or responsibility for the accuracy, completeness, or usefulness of any information, apparatus, product, process, method, or policy contained herein; or
- (3) represents that its use would not infringe any privately owned rights, including, but not limited to, patents, trademarks, or copyrights.

This program is funded by California utility customers and administered by Pacific Gas and Electric Company under the auspices of the California Public Utilities Commission.

Contents

	Page
Executive Summary	iii
1 Introduction	1-1
Background	1-1
Objective	1-2
Appliance Description	1-2
2 Methods	2-1
Setup and Instrumentation	2-1
Energy Input Rate and Thermostat Calibration	2-2
Preheat and Idle Rate Tests	2-2
Light Load Pizza Efficiency Tests	2-3
Medium Load Pizza Efficiency Tests	2-5
Heavy Load Pizza Efficiency and Production Capacity Tests	2-6
3 Results	3-1
Energy Input Rate and Thermostat Calibration	3-1
Preheat and Idle Rate Tests.....	3-1
Cooking Tests	3-3
4 Conclusions	4-1
5 References	5-1
Appendix A: Glossary	
Appendix B: Appliance Specifications	
Appendix C: Results Reporting Sheets	
Appendix D: Cooking Energy Efficiency Data	

List of Figures and Tables

Figures		Page
2-1	The Air Deck Oven instrumented for testing	2-2
2-2	Thermocouple Probe Structure	2-4
3-1	Preheat Characteristics	3-2

Tables		Page
1-1	Appliance Specifications	1-3
3-1	Input, Preheat, and Idle Rate Test Results	3-2
3-2	Cooking Energy Efficiency and Production Capacity Test Results.....	3-4

Executive Summary

The Garland® Air Deck™ model G56PB is a gas fired deck oven with a 48-inch wide cook chamber and an 80,000 Btu/h burner. The unique design of the Air Deck oven incorporates air impingement technology to cook using forced hot air. Patented stainless steel “jet plates” are used on the floor and roof of the oven cavity so air can be introduced both above and below the food being cooked. Hot air generated in the burner is moved by a fan into air plenums, where it then passes through the jet plates and into the oven cavity. The upper and lower air velocities are independently controlled through the use of adjustable air dampers.

The Food Service Technology Center (FSTC) tested the G56PB oven under the tightly controlled conditions of the American Society for Testing and Materials’ (ASTM) Standard Test Method.¹ Oven performance is characterized by preheat energy consumption and duration, idle energy rate, cooking energy efficiency and production capacity.

The Garland G56PB was set up and operated in accordance with the manufacturer’s specifications, and operated consistently and reliably in all phases of the testing process.

Cooking energy efficiency and production capacity results are obtained from the cooking of standardized test pizzas under light load, medium load, and heavy load testing scenarios. A summary of the test results is presented in Table ES-1.

Executive Summary

Table ES-1. Summary of Performance: Garland Air Deck oven, Model G56PB.

Preheat and Idle Rate Tests

Rated Energy Input Rate (Btu/h)	80,000
Measured Energy Input Rate (Btu/h)	82,500
Percentage Difference From Rated (%)	3.1
Fan / Control Energy Rate (kW)	0.6
Preheat Time (min)	15.5
Preheat Energy (Btu)	21,800
Idle Energy Rate (Btu/h)	34,200
Percentage of Input (%)	42

Light Load Pizza Efficiency Tests (1 pizza)

Cook Time (min)	4.75
Average Test Time (min)	4.75
Cooking Energy Efficiency (%)	5.6 ± 0.5
Gas Cooking Energy Rate (Btu/h)	39,900
Electric Cooking Energy Rate (kW)	0.6
Average Production Rate (pizzas/h)	12.6

Medium Load Pizza Efficiency Tests (6 pizzas)

Cook Time (min)	4.75
Average Test Time (min)	4.8
Cooking Energy Efficiency (%)	19.7 ± 0.6
Gas Cooking Energy Rate (Btu/h)	62,400
Electric Cooking Energy Rate (kW)	0.6
Average Production Rate (pizzas/h)	75.0

Heavy Load Pizza Efficiency and Production Capacity Tests (12 pizzas)

Cook Time (min)	5.0
Average Test Time (min)	5.7
Cooking Energy Efficiency (%)	30.3 ± 0.9
Cooking Energy Rate (Btu/h)	70,800
Electric Energy Rate (kW)	0.6
Average Production Capacity (pizzas/h)	125.7

Executive Summary

The Garland Air Deck oven is unique to the deck oven appliance category with its use of air impingement technology, allowing food to cook by convection, rather than by conduction and radiation.

The adjustable air dampers allow hot air velocities to be tailored to the food being cooked, and this feature, combined with the ability to independently load and unload food items, gives the Air Deck oven the flexibility to adapt to different food products and varying menus.

Performance tests on the Air Deck oven show a preheat time of 15.5 minutes and an idle energy rate of 34,200 Btu/h. Test pizzas were cooked in 4.75 minutes during light and medium load testing, with cooking energy efficiencies of 5.6% and 19.7% respectively. Test pizzas were cooked in 5.0 minutes during heavy load testing with a cooking energy efficiency of 30.3%, and a production capacity of 125.7 pizzas/h.

FSTC Manager

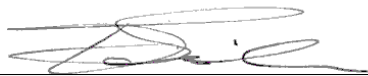

Donald R. Fisher

Senior Program Manager



Peter W. Turnbull

1 Introduction

Background

In the Garland Air Deck oven, the traditional hearth has been replaced with patented, stainless steel “jet plates” and adjustable air dampers to create a deck oven which cooks using air impingement.

Deck ovens have long been used in the food service industry as a flexible appliance capable of cooking many types of food product. The oven floor, or hearth, is usually a stone, ceramic, or steel plate, and food is cooked by both conduction from this heated surface, and by radiant heat from the surrounding oven cavity. In the Garland® Air Deck™ oven, the traditional hearth has been replaced with patented, stainless steel “jet plates” and adjustable air dampers to create a deck oven which cooks using air impingement. This technology draws heated air through a fan, which forces it into air plenums, and then through hundreds of ports in the jet plates to “impinge” hot air onto the food being cooked. With forced air being introduced at both the top and bottom of the oven cavity, food is cooked by convection in the Air Deck oven, instead of conduction and radiation.

While initial capital cost is a determining factor in the selection of new food service equipment, appliances can also be evaluated with regards to long-term operational cost and performance as characterized by cooking energy efficiency, idle energy consumption and production capacity.

With support from the Electric Power Research Institute (EPRI) and the Gas Research Institute (GRI), Pacific Gas and Electric Company’s Food Service Technology Center (FSTC) developed a uniform testing procedure to evaluate the performance of gas and electric deck ovens. This test procedure was submitted to the American Society for Testing and Materials (ASTM) and accepted as a standard test method (Designation F 1965-99) in 1999.¹ Pacific Gas and Electric Company’s *Development and Validation of a*

Introduction

Uniform Testing Procedure for Deck Ovens documents the developmental procedures and test results of several gas and electric deck ovens.²

Objective

The objective of this report is to examine the operation and performance of the Garland Air Deck gas deck oven, model G56PB, under the controlled conditions of the ASTM Standard Test Method. The scope of this testing is as follows:

1. Thermostat accuracy is checked at a setting of 475°F and the thermostat is adjusted if necessary.
2. Energy input rate is determined to confirm that the oven is operating within 5% of the nameplate energy input rate.
3. Preheat energy and time are determined.
4. Idle energy rate is determined at a thermostat set point of 475°F.
5. Cooking energy efficiency and production rate are determined during light, medium, and heavy load cooking tests using pizza as a food product.

Appliance Description

The Garland Air Deck oven, model G56PB, is a gas fired deck oven using air impingement technology. The oven has a 48-inch wide by 36-inch deep deck surface and an input rate of 80,000 Btu/h. Exterior surfaces are a combination of painted steel and stainless steel, while interior surfaces are aluminized steel. When running, the oven draws heated air through a fan which forces it into separate air plenums, and then through patented jet plates at both the top and bottom of the oven cavity. Air dampers allow the velocity of air passing through each jet plate to be adjusted. Oven controls consist of a dial for temperature set point and a rocker switch to turn the oven on and off.

Appliance specifications are listed in Table 1-1, and the manufacturer's literature is included in Appendix B.

Introduction



Table 1-1. Appliance Specifications.

Manufacturer	Garland Commercial Industries, Inc.
Model	G56PB
Generic Appliance Type	Deck Oven
Rated Input	80,000 Btu/h
Technology	Air Impingement
Construction	Painted and Stainless Steel Exterior Aluminized Steel Interior
Controls	Dial Type Thermostat Adjustment Rocker Type On/Off Switch
Deck Size	48" Wide × 36" Deep
Dimensions	63" Wide × 55" Tall × 50" Deep

2 Methods

Setup and Instrumentation

The G56PB oven was installed in accordance with the manufacturer's instructions and Section 9 of the ASTM standard test method.¹ The oven was positioned on a tiled floor under a 4-foot-deep canopy hood, with the lower edge of the hood 6 feet, 6 inches above the floor and the oven a minimum of 6 inches inside the vertical front edge of the hood. The exhaust ventilation operated at a nominal rate of 300 cfm per linear foot of hood.

During all phases of testing, the air dampers on the oven were adjusted with the upper damper in the ½ open position, and the lower damper in the fully open position. These are the settings recommended by the manufacturer for a cheese pizza with par-baked crust.

Gas consumption was monitored using a positive displacement meter which generated a pulse for every 0.1 ft³ of gas used. Power and energy were measured with a watt/watt-hour transducer that generated a pulse for each Wh used. Oven cavity temperature was monitored with a 24 gauge, type K, Teflon insulated thermocouple wire located in the geometric center of the oven cavity. The transducer and thermocouples were connected to a computerized data acquisition unit that recorded data every 5 seconds.

Figure 2-1 shows the G56PB instrumented with the data acquisition system.

Methods



*Figure 2-1.
The Air Deck oven
Instrumented for
Testing.*

Energy Input Rate and Thermostat Calibration

The energy input rate was determined by turning the oven on and measuring the gas consumed from the time the burners first ignited until the time when the burners first cycled off. The gas consumed and the time elapsed were used to calculate the maximum energy input rate. Thermostat calibration was verified by allowing the oven to operate with the thermostat set to the specified operating temperature of 475°F for a period of one hour and then monitoring the oven cavity temperature for a period of thirty minutes. If the average oven temperature during the thirty minutes was more than 480°F or less than 470°F, the controls were adjusted, the oven was allowed to re-stabilize at the new temperature for a period of one hour, and the cavity temperature was again monitored for a period of thirty minutes. This process was repeated until the oven temperature was within the $475 \pm 5^\circ\text{F}$ bandwidth.

Preheat and Idle Rate Tests

Preheat tests recorded the time and energy required for the oven to increase the cavity temperature from $75 \pm 5^\circ\text{F}$ to a temperature of 465°F. Recording began when the oven was first turned on, so any time delay before the

Methods

ignition of the burners was included in the test. Although the specified operating temperature is 475°F, research at Pacific Gas and Electric Company's Food Service Technology Center has indicated that a deck oven is sufficiently preheated and ready to cook when the oven temperature is within 10°F of the oven set point.

After the oven was preheated, it was allowed to stabilize for one hour, and then idle energy consumption was monitored for a 2-hour period.

Light Load Pizza Efficiency Tests

Light load pizza tests were used to calculate the cooking energy efficiency of the oven when cooking a single pizza.

The cooking energy efficiency tests were performed with a uniform test pizza as the food product. Pizza crusts were 12-inch diameter, par-baked crusts weighing 0.9 ± 0.2 lb and having a moisture content of $36 \pm 3\%$ by weight. Pizza sauce was a simple, tomato based sauce with a moisture content of $87 \pm 3\%$ by weight. Pizza cheese was part-skim, low moisture, shredded mozzarella cheese with a moisture content of $50 \pm 2\%$ by weight. Ingredients were verified for proper moisture content by gravimetric moisture analysis.

The pizzas were comprised of a pizza crust, pizza sauce and pizza cheese according to the following: 0.25 lb of pizza sauce spread uniformly on top of a pizza crust to within 0.5 inch of the edge and 0.375 lb of pizza cheese spread uniformly over the pizza sauce. The prepared pizzas were placed on sheet pans and covered with plastic wrap. The pizzas were stabilized in a refrigerator for a minimum of 18 hours before testing to ensure temperature uniformity of $39 \pm 1^\circ\text{F}$.

Pizza doneness requires a final pizza temperature of $195 \pm 3^\circ\text{F}$. During temperature determination, the pizzas were placed on a piece of rigid polystyrene insulation that was covered with a sheet of waxed paper. The final pizza temperature was measured by placing six hypodermic-style

Methods

thermocouple probes on the surface of the pizza, located 3 inches from the center of the pizza and equidistant from each other. The probes were allowed to penetrate the cheese and rest in the sauce-crust interface. The highest average temperature of the six probes during measurement was the final pizza temperature. For consistency and simplicity, the probes were attached to a lightweight plastic disc which held the relative position of each probe constant from pizza to pizza. Figure 2-2 shows the thermocouple probe structure.

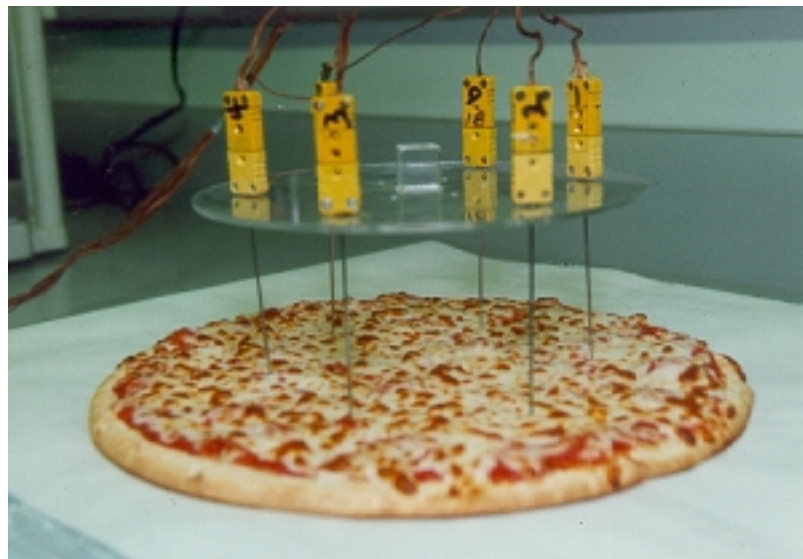

*Figure 2-2.
Thermocouple Probe
Structure.*

For convenience, the pizzas were pre-weighed so only the final after-cook weight needed to be taken during the test. For each light-load test run, a single pizza was placed in the deck oven, centered in the oven cavity. No more than 1 minute elapsed between removal from the refrigerator and the beginning of the cooking process. Loading of the pizza was also coordinated with the cycling of the oven so that the door could be opened, and the pizza loaded, immediately after the burner cycled off. Cook time monitoring began

Methods

when the pizza first came into contact with the oven deck. After cooking, the pizza was removed and probed for final temperature determination. The pizza was then weighed to calculate the amount of moisture lost during cooking. Test time and energy consumption continued to be monitored until the oven cavity had recovered to a temperature of 465°F.

Medium Load Pizza Efficiency Tests

The medium load pizza tests were used to calculate cooking energy efficiency under partial loading conditions, as when an oven is cooking pizzas at a rate less than its maximum capacity.

The medium load tests required preparation of 6 pizzas for each test run. The pizzas were prepared, pre-weighed and stabilized as in the light load tests. Immediately after the oven cycled off, the pizzas were loaded into the oven from back to front and from left to right, as outlined in the ASTM Test Method.

After cooking, the pizzas were removed from front to back and from left to right. The first pizza removed, the third pizza removed, and the fifth pizza removed were probed for final temperature determination. All pizzas had final weights measured for use in the energy efficiency calculations.

The test procedure indicates that the last pizza removed from the oven is to be used for final temperature determination; however, hot air being introduced to the oven directly above the final pizza cooked it noticeably faster than the others, causing its final temperature to be out of the $195 \pm 3^\circ\text{F}$ range. This slight variation in temperature uniformity made it impossible for the researchers to properly complete the testing in accordance with the intentions of the test method. Therefore, during this phase of testing, the second to last, or fifth, pizza removed was used for final temperature determination. This variation from the standard testing procedures was noted on the results reporting sheets.

Methods

Heavy Load Pizza Efficiency and Production Capacity Tests

The heavy load pizza tests were used to calculate cooking energy efficiency and production capacity when the oven was under maximum loading conditions.

The heavy load tests required preparation of 12 pizzas for each test run. The pizzas were prepared, pre-weighed and stabilized as in the light and medium load tests. Immediately after the oven cycled off, the pizzas were loaded into the oven from back to front and from left to right, as outlined in the ASTM Test Method. After cooking, the pizzas were removed from front to back and from left to right. The first pizza removed, the sixth pizza removed, and the last pizza removed were probed for final temperature determination. All pizzas had final weights measured for use in the energy efficiency calculations.

Each test load scenario- light, medium and heavy, was applied in triplicate and a statistical analysis of the results was performed to ensure that the reported cooking energy efficiency and production capacity results had an uncertainty of less than 10%. Application of the statistical analysis is detailed in Annex A1 of the ASTM Standard Test Method.

The ASTM results reporting sheets appear in Appendix C, and the cooking energy efficiency data sheets appear in Appendix D of this report.

3 Results

Energy Input Rate and Thermostat Calibration

The energy input rate was measured and compared with the manufacturer's nameplate value to ensure the oven was operating within its specified parameters. The maximum energy input rate was 82,500 Btu/h, 3.1% higher than the nameplate rate of 80,000 Btu/h, but within the 5% tolerance of the ASTM standard. The oven cavity temperature was monitored to verify that the oven was operating at $475 \pm 5^\circ\text{F}$. At the thermostat set point of 475°F the oven cavity temperature averaged 469.3°F , which is below the operating window. The thermostat was adjusted to 480°F , which gave an average oven cavity temperature of 475.0°F , so the 480°F setting was used for all tests.

Preheat and Idle Rate Tests

Preheat Energy and Time

Time and energy were monitored starting from the time the oven was first turned on. Any time that elapsed before the ignition of the burners was included in the test time. The preheat test ended at the specified temperature of 465°F , and consumed 21,800 Btu over a period of 15.5 min.

Idle Energy Rate

The oven was allowed to stabilize for one hour following the preheat test with the thermostat set to 480°F which held the average oven temperature at $475 \pm 5^\circ\text{F}$. After this stabilization, the energy consumption was monitored over a 2-hour period. The idle energy rate was calculated to be 34,200 Btu/h, which is 42% of the oven's rated input.

Results

Test Results

The oven's preheat curve is shown in Figure 3-1. The measured energy input rate, preheat, and idle energy rate test results are summarized in Table 3-1.

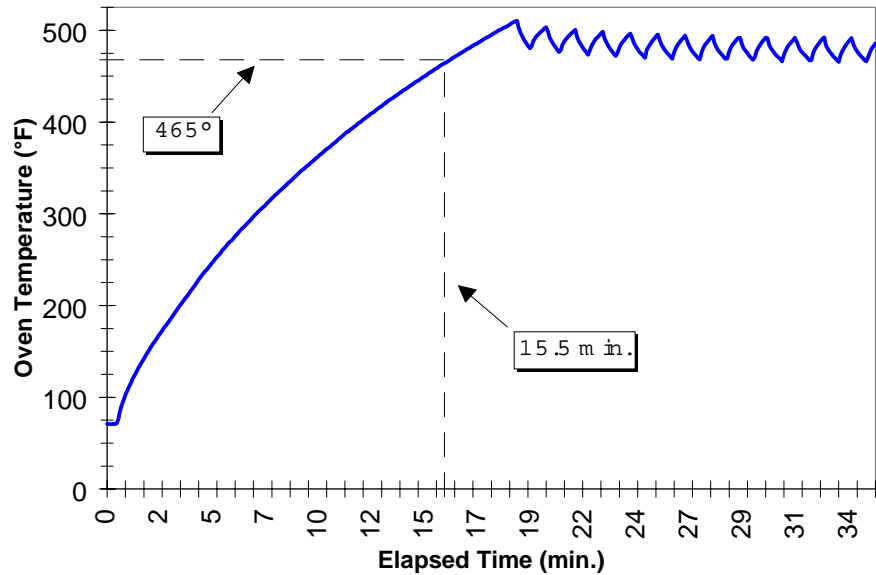

Figure 3-1.
Preheat Characteristics.

Table 3-1. Input, Preheat, and Idle Rate Test Results.

Rated Energy Input Rate (Btu/h)	80,000
Measured Energy Input Rate (Btu/h)	82,500
Percentage Difference From Rated (%)	3.1
Preheat	
Time (min)	15.5
Energy (Btu)	21,800
Idle Energy Rate	
Energy Rate (Btu/h)	34,200
Percentage of Input (%)	42

Results

Cooking Tests

Light-load pizza, medium-load pizza, and heavy-load pizza cooking tests were applied to the oven to determine cooking energy efficiency and production capacity. The gas consumption, electric energy consumption, elapsed cook time, oven cavity temperature, and ambient temperature were monitored for the duration of each test at five second intervals. During final pizza temperature determination, the readings of the temperature probes were also recorded at five second intervals.

Light Load Pizza Efficiency Tests

The light load tests were used to determine the oven's performance while cooking a single pizza. The cook time was 4.75 minutes, and the G56PB oven completed the test in 4.75 minutes, while delivering 5.6% cooking efficiency at a production rate of 12.6 Pizza/h.

Medium Load Pizza Efficiency Tests

The medium load tests were conducted to determine the oven's performance under partial load conditions. The cook time was 4.75 minutes, and the G56PB oven completed the test in an average time of 4.8 minutes, while delivering 19.7% cooking efficiency at a production rate of 75.0 pizza/h.

Heavy Load Pizza Efficiency and Production Capacity Tests

The heavy load tests were used to determine the oven's performance when operating the oven at its maximum capacity. The cook time was 5.0 minutes, and the G56PB oven completed the test in an average of 5.7 minutes, while delivering 30.3 % cooking efficiency and a production capacity of 125.7 pizza/h.

Results

Test Results

Cooking energy efficiency is defined as the quantity of energy consumed by the pizzas expressed as a percentage of energy consumed by the oven during the cooking test. The mathematical expression is:

$$\text{Cooking Energy Efficiency \%} = \frac{E_{\text{pizza}}}{E_{\text{oven}}} \times 100\%$$

Energy imparted into the pizza is calculated using the measured values of initial and final pizza temperature, initial and final pizza weight, the specific heat of the pizza (based on the average specified pizza), and the heat of vaporization of water at 212°F. Energy consumed by the test oven is determined by adding gas and electric energy use during the test. Appendix D lists the physical properties and measured values of all the test variables for each test run. Using the detailed equations provided in Section 11 of the deck oven ASTM Standard Test Method, the cooking energy efficiencies can be readily calculated. Table 3-2 summarizes the cooking energy efficiency and production capacity test results for the G56PB oven.

Table 3-2. Cooking Energy Efficiency and Production Capacity Test Results.

	Light Load Pizza	Medium Load Pizza	Heavy Load Pizza
Number of Pizzas	1	6	12
Cook Time (min)	4.75	4.75	5.0
Test Time (min)	4.75	4.8	5.7
Gas Cooking Energy Rate (Btu/h)	39,900	62,400	70,800
Electric Cooking Energy Rate (kW)	0.6	0.6	0.6
Cooking Energy Efficiency (%)	5.6	19.7	30.3
Production Rate (pizzas/h)	12.6	75.0	-
Production Capacity (pizzas/h)	-	-	125.7

4 Conclusions

By incorporating air impingement technology into their Air Deck oven, Garland Commercial Industries, Inc. has produced a unique variation of a traditional appliance.

By incorporating air impingement technology into their Air Deck oven, Garland Commercial Industries, Inc. has produced a unique variation of a traditional appliance. Patented stainless steel “jet plates” are used on the floor and roof of the oven cavity so air can be introduced both above and below the food being cooked. Hot air generated in the burner is moved by a fan into air plenums, where it then passes through the jet plates and into the oven cavity. The upper and lower air velocities are independently controlled through the use of adjustable air dampers.

During testing, the Air Deck oven preheated to 465°F in 15.5 minutes while consuming 21,800 Btu of energy. When idling, the oven used 34,200 Btu/h, which is 42% of its rated input. Test pizzas were cooked in 4.75 minutes for the light and medium load tests, and in 5.0 minutes for the heavy load tests. Average test times were 4.75 minutes for the light load tests, 4.8 minutes for the medium load tests, and 5.7 minutes for the heavy load tests. Cooking energy efficiencies were 5.6% for the light loads, 19.7% for the medium loads, and 30.3% for the heavy loads. Production rates during light and medium load tests were 12.6 pizzas/h and 75.0 pizzas/h, respectively, and production capacity during the heavy loads tests was 125.7 pizzas/h.

With its unique air impingement heat transfer technology and the flexibility afforded by a deck type oven, the Garland Air Deck oven model G56PB would be a valuable addition to any kitchen considering a deck type oven.

5 References

1. American Society for Testing and Materials. 1999. *Standard Test Method for the Performance of Deck Ovens*. ASTM Designation F 1965-99, in *Annual Book of ASTM Standards*, Philadelphia: American Society for Testing and Materials.
2. Pacific Gas and Electric Company. Publication Pending. *Development and Validation of a Uniform Testing Procedure for Deck Ovens*.

Appendixes

A Glossary

Cook Time

Time (min.) required for the deck oven to bring the specified food product to a specified “cooked” condition.

Cooking Energy Efficiency

Energy Efficiency

Quantity of energy imparted to the specified food product expressed as a percentage of energy consumed by the deck oven during the cooking event.

Cooking Energy Rate

Cooking Energy Consumption Rate

Average rate of energy consumption (Btu/h or kW) during the cooking energy efficiency test. Refers to all loading scenarios (light, medium, heavy).

Deck Oven

An appliance that cooks the food product within a heated chamber. The food product can be placed directly on the floor of the chamber during cooking, and energy may be delivered to the food product by convective, conductive and/or radiant heat transfer. The chamber may be heated by gas or electric forced convection, radiants, or quartz tubes. Top and bottom heat may be independently controlled.

Energy Input Rate

Rate at which a deck oven consumes energy (Btu/h or kW).

Idle Energy Rate

Idle Rate

The deck oven’s rate of energy consumption (kW or Btu/h), when empty, required to maintain its cavity temperature at the specified thermostat set point.

Oven Cavity

That portion of the deck oven in which food products are heated or cooked.

Pilot Energy Rate

Rate of energy consumption (Btu/h) by a deck oven’s continuous pilot (if applicable).

Preheat Energy

Amount of energy consumed (Btu/h or kWh) by the deck oven while preheating its cavity from ambient temperature to the specified thermostat set point.

Preheat Time

Time (min.) required for the deck oven cavity to preheat from ambient temperature to the specified thermostat set point.

Production Capacity

Maximum rate (lb(kg)/h) at which a deck oven can bring the specified food product to a specified “cooked” condition.

Production Rate

Rate (lb(kg)/h) at which a deck oven can bring the specified food product to a specified “cooked” condition.

Glossary

Test Time

Time (min.) required for the deck oven to complete a cooking test. Includes cook time, plus any time necessary for the oven cavity to recover to 465°F.

Uncertainty

Measure of systematic and precision errors in specified instrumentation or measure of repeatability of a reported test result.

B Appliance Specifications

Appendix B includes the product literature for the Garland Air Deck gas deck oven, Model G56PB.



Model G56PT

Specifications:

Unique energy delivery system driven by controlled hot air flow designed for high volume operation. Offers minimum preheat time; no recovery time; consistent selected temperatures; high quality production, and menu versatility. Available in natural or propane gas.



Standard Features:

- Stainless Steel Front, Sides, Top, and Legs
- Porcelainized Control Panel
- Full Deck Width, Balanced Spring-Loaded Door
- Stainless Steel Perforated Deck
- Adjustable Legs
- Electronic Ignition
- Snap Action Thermostat (550° F Max.)
- Heat Control Damper System
- Forced Air Combustion Burner; 80,000 BTU
- Single Speed Fan with ¾ HP Motor
- 56"W x 36"D Deck Surface
- 63"W x 45"D Floor Space
- 53"W x 7½"H Door Opening
- One Year Limited Parts and Labor Warranty (USA & Canada only)

Optional Features:

- Stainless Steel Back
- Timer Packages - One and Three section
- Direct Connect Vent - No charge
- Warming Rack
- Peel Holder



Model G56PT/B

Garland Commercial Industries, Inc.
 185 East South Street
 Freeland, Pennsylvania 18224
 Phone: (570) 636-1000
 Fax: (570) 636-3903

Garland Commercial Ranges Ltd
 1177 Kamato Road, Mississauga, Ontario
 L4W 1X4 CANADA
 Phone: 905-624-0260
 Fax: 905-624-5669

Enodis UK LTD
 Swallowfield Way, Hayes, Middlesex
 UB3 1DQ ENGLAND
 Telephone: 081-561-0433
 Fax: 081-848-0041



Item #: _____

Models: G56PB, G56PT, G56PT/B

Product Name: Air-Deck™ Gas Deck Oven

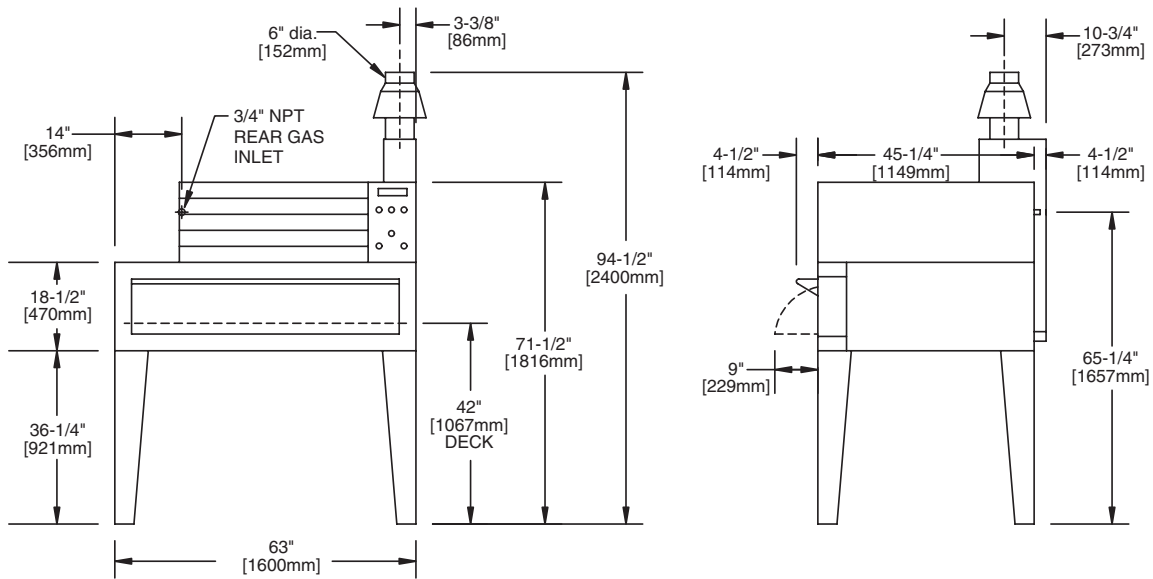

Single deck with top power module and Direct Connect Venting.

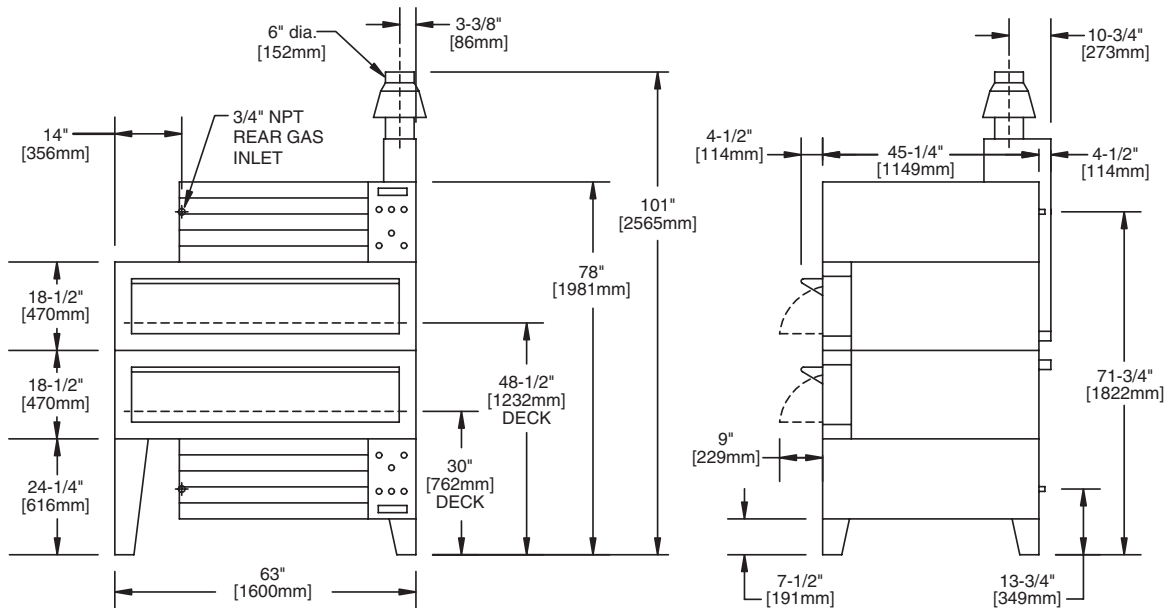

Double Deck: (1) top power module, (1) bottom power module and Direct Connect Venting.

MODEL	INPUT (BTU)	DECK AREA	PIZZA CAPACITY	MOTOR	SHIPPING WT.
G56PB	80,000	14.0 Sq. Ft.	(6) 18"	120V, 1PH, 60Hz 15 Amps (1 per deck)	1000 lbs. 455 kg
G56PT	80,000	14.0 Sq. Ft.	(6) 18"		1000 lbs. 455 kg
G56PT/B	160,000	28.0 Sq. Ft.	(12) 18"		2@1000 lbs. 910 kg

Gas input ratings shown here are for installations tip to 2,000 feet (610m) above sea level.
BTU input ratings must be derated for high altitude installations.

MANIFOLD PRESSURE		MINIMUM CLEARANCES				
		Installation to Combustible Wall			Entry	
NAT	PRO	Sides	Rear	Base	Crated	Uncrated
3.5" WC	10.0" WC	6" (152mm)	6" (152mm)	8" (203mm)	45" (1143mm)	35-1/2" (902mm)

Continuous product improvement is a Garland policy.

C Results Reporting Sheets

Manufacturer Garland Commercial Industries, Inc.
Model G56PB
Serial # 9606AG0020
Date: July, 99
Test Reference Number
(optional) N/A

Section 11.1 Test Oven

Description of operational characteristics:

The oven draws heated air through a fan which forces it into separate air plenums, then through patented "jet plates" above and below the oven cavity. Air dampers control the amount of hot air for both top and bottom jet plates. All controls are mounted on the front of the oven.

Physical Dimensions

Size of Oven: 55 H × 63 W × 50 D inches
Oven deck width: 54 inches
Oven deck depth: 36 inches
Nominal oven deck width: 4 feet
Nominal oven deck depth: 3 feet

Section 11.2 Apparatus

√ Check if testing apparatus conformed to specifications in section 6

Deviations:

During medium load pizza testing, the fifth pizza, instead of the sixth pizza, was used for final temperature determination due to a localized variation in temperature uniformity.

Results Reporting Sheets

Section 11.4 Energy Input Rate

Test Voltage (V)	<u>N/A</u>
Gas Heating Value (Btu/ft ³)	<u>1021.9</u>
Rated (<u>Btu/h</u> or kW)	<u>80,000</u>
Measured (<u>Btu/h</u> or kW)	<u>82,500</u>
Percent Difference between Measured and Rated (%)	<u>3.1</u>
Fan / Control Energy Rate (kW, gas ovens only)	<u>0.6</u>

Section 11.5 Preheat Energy and Time

Test Voltage (V)	<u>N/A</u>
Gas Heating Value (Btu/ft ³)	<u>1024.1</u>
Energy Consumption (<u>Btu</u> or kWh)	<u>21,800</u>
Time from <u>75</u> °F to 465°F (min)	<u>15.5</u>

Preheat Characteristics

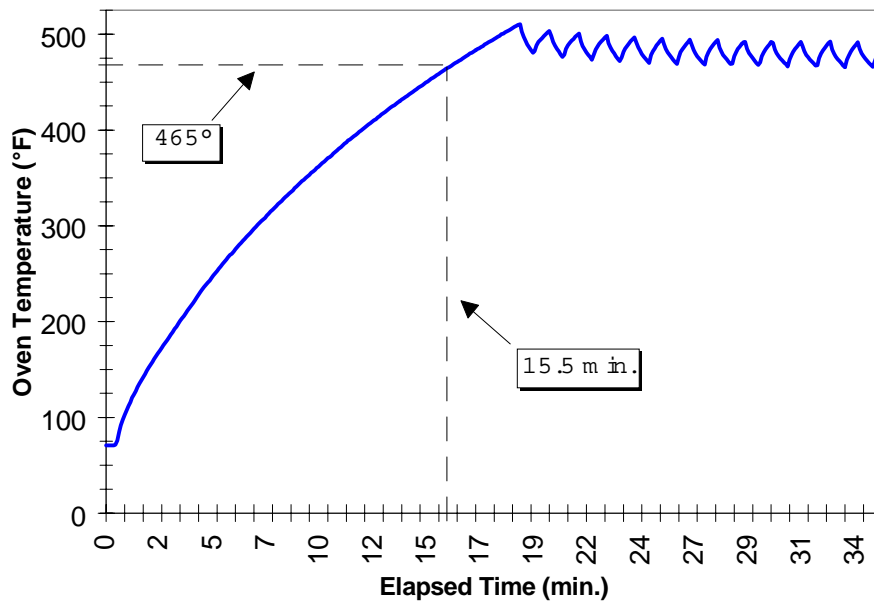

Results Reporting Sheets

Section 11.6 Idle Energy Rate

Test Voltage (V)	<u>N/A</u>
Gas Heating Value (Btu/ft ³)	<u>1021.9</u>
Idle Energy Rate (<u>Btu/h</u> or kW)	<u>34,200</u>

Section 11.7 Pilot Energy Rate

Gas Heating Value	<u>N/A</u>
Pilot Energy Rate	<u>N/A</u>

Section 11.8 Cooking Energy Efficiency and Cooking Energy Rate

Cook Time Determination:

Cook Time: 4.75 min

Light Load:

Test Voltage (V)	<u>N/A</u>
Gas Heating Value (Btu/ft ³)	<u>1023.6</u>
Cooking Energy Efficiency (%)	<u>5.6 ± 0.5</u>
Cooking Energy Rate (<u>Btu/h</u> or kW)	<u>39,900</u>
Electric Energy Rate (kW, gas ovens only)	<u>0.6</u>
Energy into Food - E_{food} (Btu)	<u>186</u>
Energy into the appliance - $E_{appliance}$ (Btu)	<u>3330</u>
Final cooktime (min)	<u>4.75</u>
Production Rate (pizzas/h)	<u>12.6</u>

Medium Load:

Test Voltage (V)	<u>N/A</u>
Gas Heating Value (Btu/ft ³)	<u>1023.7</u>
Cooking Energy Efficiency (%)	<u>19.7 ± 0.6</u>
Cooking Energy Rate (<u>Btu/h</u> or kW)	<u>62,400</u>
Electric Energy Rate (kW, gas ovens only)	<u>0.6</u>

Results Reporting Sheets

Energy into Food - E_{food} (Btu)	<u>1020</u>
Energy into the appliance - $E_{appliance}$ (Btu)	<u>5170</u>
Final cooktime (min)	<u>4.75</u>
Production Rate (pizzas/h)	<u>75.0</u>

Heavy Load:

Test Voltage (V)	<u>N/A</u>
Gas Heating Value (Btu/ft ³)	<u>1026.1</u>
Cooking Energy Efficiency (%)	<u>30.3 ± 0.9</u>
Cooking Energy Rate (<u>Btu/h</u> or kW)	<u>70,800</u>
Electric Energy Rate (kW, gas ovens only)	<u>0.6</u>
Energy into Food - E_{food} (Btu)	<u>2120</u>
Energy into the appliance - $E_{appliance}$ (Btu)	<u>6960</u>
Final cooktime (min)	<u>5.0</u>
Production Capacity (pizzas/h)	<u>125.7</u>

D Cooking Energy Efficiency Data

Table D-1. Physical Properties.

Specific Heat (Btu/lb °F)		
Pizza		0.593
Latent Heat (Btu/lb)		
Vaporization, Water		970

Table D-2. Light Load Pizza Efficiency Test Data.

Measured Values	Repetition #1	Repetition #2	Repetition #3
Number of Pizzas	1	1	1
Initial Pizza Temperature (°F)	40	40	40
Final Average Pizza Temperature (°F)	197.8	193.5	196.5
Total Initial Pizza Weight (lb)	1.438	1.439	1.423
Total Final Pizza Weight (lb)	1.384	1.387	1.365
Test Time (min.)	4.75	4.75	4.75
Gas Volume (ft ³)	3.5	3.2	3.3
Electric Energy (Wh)	50	50	50
Calculated Values			
Energy Consumed by Pizzas (Btu)	187	181	188
Gas Energy Consumed by Oven (Btu)	3320	3030	3130
Electric Energy Consumed by Oven (Btu)	170	160	170
Total Energy Consumed by Oven(Btu)	3490	3190	3300
Cooking Energy Efficiency (%)	5.4	5.7	5.7
Gas Cooking Energy Rate (Btu/h)	41,900	38,300	39,500
Electric Cooking Energy Rate (kW)	0.6	0.6	0.6
Production Rate (Pizzas/h)	12.6	12.6	12.6

Cooking Energy Efficiency Data

Table D-3. Medium Load Pizza Efficiency Test Data.

Measured Values	Repetition #1	Repetition #2	Repetition #3
Number of Pizzas	6	6	6
Initial Pizza Temperature (°F)	40	40	40
Final Average Pizza Temperature (°F)	195.0	193.9	196.3
Total Initial Pizza Weight (lb)	8.501	8.583	8.604
Total Final Pizza Weight (lb)	8.280	8.320	8.380
Test Time (min.)	4.75	4.9	4.75
Gas Volume (ft ³)	5.2	5.4	5.2
Electric Energy (Wh)	50	50	50
Calculated Values			
Energy Consumed by Pizzas (Btu)	1000	1040	1020
Gas Energy Consumed by Oven (Btu)	4940	5120	4930
Electric Energy Consumed by Oven (Btu)	170	170	170
Total Energy Consumed by Oven(Btu)	5110	5290	5100
Cooking Energy Efficiency (%)	19.5	19.6	19.9
Gas Cooking Energy Rate (Btu/h)	62,400	62,700	62,200
Electric Cooking Energy Rate (kW)	0.6	0.6	0.6
Production Rate (Pizzas/h)	75.8	73.5	75.8

Cooking Energy Efficiency Data

Table D-3. Heavy Load Pizza Efficiency Test Data.

Measured Values	Repetition #1	Repetition #2	Repetition #3
Number of Pizzas	12	12	12
Initial Pizza Temperature (°F)	40	40	40
Final Average Pizza Temperature (°F)	193.5	195.0	196.8
Total Initial Pizza Weight (lb)	17.190	17.156	17.228
Total Final Pizza Weight (lb)	16.700	16.580	16.660
Test Time (min.)	5.5	5.9	5.8
Gas Volume (ft ³)	6.7	7.2	7.1
Electric Energy (Wh)	60	60	60
Calculated Values			
Energy Consumed by Pizzas (Btu)	2040	2140	2150
Gas Energy Consumed by Oven (Btu)	6510	6940	6840
Electric Energy Consumed by Oven (Btu)	190	200	200
Total Energy Consumed by Oven(Btu)	6700	7140	7040
Cooking Energy Efficiency (%)	30.4	29.9	30.6
Gas Cooking Energy Rate (Btu/h)	71,000	70,600	70,700
Electric Cooking Energy Rate (kW)	0.6	0.6	0.6
Production Capacity (Pizzas/h)	130.9	122.0	124.1

Cooking Energy Efficiency Data

Table D-6. Cooking Energy Efficiency Statistics.

	Light Load	Medium Load	Heavy Load
Replicate #1	5.4	19.5	30.4
Replicate #2	5.7	19.6	29.9
Replicate #3	5.7	19.9	30.6
Average	5.6	19.7	30.3
Standard Deviation	0.20	0.22	0.35
Absolute Uncertainty	0.49	0.55	0.87
Percent Uncertainty	8.8	2.8	2.9
