

US Range RG TSA Gas Griddle Performance Test

Application of ASTM Standard
Test Method F 1275-99

FSTC Report 5011.03.27

**Food Service Technology Center
September 2003**

Prepared by:
David Cowen
David Zabrowski
Fisher-Nickel Inc.

Contributors:
Scott Miner
Fisher-Nickel, Inc

© 2003 by Fisher-Nickel, inc. All rights reserved.

The information in this report is based on data generated by the Food Service Technology Center.

Acknowledgments

California consumers are not obligated to purchase any full service or other service not funded by this program. This program is funded by California utility ratepayers under the auspices of the California Public Utilities Commission.

Los consumidores en California no estan obligados a comprar servicios completos o adicionales que no esten cubiertos bajo este programa. Este programa esta financiado por los usuarios de servicios publicos en California bajo la jurisdiccion de la Comision de Servicios Publicos de California.

A National Advisory Group provides guidance to the Food Service Technology Center Project. Members include:

Applebee's International Group
California Energy Commission (CEC)
California Restaurant Association
Carl Karcher Enterprises, Inc.
DJ Horton & Associates
Denny's
Electric Power Research Institute (EPRI)
Enbridge Gas Distribution
EPA Energy Star
Gas Technology Institute (GTI)
Lawrence Berkeley National Laboratories
McDonald's Corporation
National Restaurant Association
Pacific Gas and Electric Company
Safeway, Inc.
Southern California Edison
Underwriters Laboratories (UL)
University of California at Berkeley
University of California at Riverside
US Department of Energy, FEMP

Specific appreciation is extended to US Range, for supplying the Food Service Technology Center with a 3-foot gas griddles for controlled testing in the appliance laboratory.

Policy on the Use of Food Service Technology Center Test Results and Other Related Information

- Fisher-Nickel, inc. and the Food Service Technology Center (FSTC) do not endorse particular products or services from any specific manufacturer or service provider.
- The FSTC is *strongly* committed to testing food service equipment using the best available scientific techniques and instrumentation.
- The FSTC is neutral as to fuel and energy source. It does not, in any way, encourage or promote the use of any fuel or energy source nor does it endorse any of the equipment tested at the FSTC.
- FSTC test results are made available to the general public through technical research reports and publications and are protected under U.S. and international copyright laws.
- In the event that FSTC data are to be reported, quoted, or referred to in any way in publications, papers, brochures, advertising, or any other publicly available documents, the rules of copyright must be strictly followed, including written permission from Fisher-Nickel, inc. *in advance* and proper attribution to Fisher-Nickel, inc. and the Food Service Technology Center. In any such publication, sufficient text must be excerpted or quoted so as to give full and fair representation of findings as reported in the original documentation from FSTC.

Legal Notice

This report was prepared as a result of work sponsored by the California Public Utilities Commission (Commission). It does not necessarily represent the views of the Commission, its employees, or the State of California. The Commission, the State of California, its employees, contractors, and subcontractors make no warranty, express or implied, and assume no legal liability for the information in this report; nor does any party represent that the use of this information will not infringe upon privately owned rights. This report has not been approved or disapproved by the Commission nor has the Commission passed upon the accuracy or adequacy of the information in this report.

Contents

	Page
Executive Summary	iii
1 Introduction	1-1
Background	1-1
Objectives	1-2
Appliance Description	1-2
2 Methods	2-1
Setup and Instrumentation	2-1
Measured Energy Input Rate	2-2
Cooking Tests	2-2
3 Results	3-1
Energy Input Rate	3-1
Temperature Uniformity	3-1
Preheat and Idle Tests	3-4
Cooking Tests	3-5
Energy Cost Model.....	3-9
4 Conclusions	4-1
5 References	5-1
Appendix A: Glossary	
Appendix B: Appliance Specifications	
Appendix C: Results Reporting Sheets	
Appendix D: Cooking-Energy Efficiency Data	
Appendix E: Energy Cost Model	

List of Figures and Tables

Figures

		Page
1-1	US Range RG TSA 2636-1 gas griddle	1-3
2-1	Thermocouple grid for temperature uniformity test	2-1
2-2	Thermocouple placement for testing	2-3
3-1	Temperature sensing points on the griddle surface	3-2
3-2	Temperature map of the cooking surface	3-2
3-3	Preheat characteristics	3-4
3-4	Average heavy-load cooking surface temperatures	3-6
3-5	Griddle temperature signature while cooking a heavy-load of hamburgers	3-7
3-6	Griddle part-load cooking-energy efficiency	3-8
3-7	Griddle cooking energy consumption profile	3-9

Tables

		Page
1-1	Appliance Specifications	1-3
3-1	Temperature Uniformity and Thermostat Accuracy	3-3
3-2	Input, Preheat, and Idle Test Results	3-5
3-3	Cooking-Energy Efficiency and Production Capacity Test Results	3-8
3-4	Estimated Griddle Energy Consumption and Cost	3-10

Executive Summary

Griddles are widely used throughout the hospitality industry to prepare a variety of menu items, from pancakes to hamburgers. As concern over food safety continues, griddle performance parameters such as temperature uniformity and productivity are becoming more important to the food service operator.

US Range's RG TSA 2636-1 griddle features stainless steel and 14-gauge construction, snap-action thermostats, and a 1-inch thick-brushed steel cooking surface (see Figure ES-1). Food Service Technology Center (FSTC) engineers tested the 3-foot griddle under the tightly controlled conditions of the American Society for Testing and Materials' (ASTM) Standard Test Method for the Performance of Griddles.¹ Griddle performance is characterized by temperature uniformity, preheat time and energy consumption, idle energy consumption rate, cooking-energy efficiency, and production capacity.



Figure ES-1.
US Range RG TSA 2636-1
gas griddle.

Cooking-energy efficiency and production capacity were determined by cooking frozen hamburgers under three different loading scenarios (heavy—24 hamburgers, medium—12 hamburgers, and light—4 hamburgers). The cook time for the heavy-load cooking scenarios was 8.47 minutes. Production capacity includes the cooking time and the time required for the cooking surface to return to within 25°F of the thermostat set point. Production rate varies with the amount of food being cooked.

Cooking-energy efficiency is a measure of how much of the energy that an appliance consumes is actually delivered to the food product during the cooking process. Cooking-energy efficiency is therefore defined by the following relationship:

$$\text{Cooking - Energy Efficiency} = \frac{\text{Energy to Food}}{\text{Energy to Appliance}}$$

¹ American Society for Testing and Materials. 1999. *Standard Test Method for the Performance of Griddles*. ASTM Designation F 1275-99, in *Annual Book of ASTM Standards*, West Conshohocken, PA.

Executive Summary

A summary of the ASTM test results is presented in Table ES-1.

Table ES-1. Summary of Griddle Performance.

Rated Energy Input Rate (Btu/h)	72,000
Measured Energy Input Rate (Btu/h)	71,622
Temperature Uniformity (°F) ^a	± 39
Useable cooking surface area (in ²) ^b	541
Preheat Time to 375°F (min)	15.6
Preheat Energy to 375°F (Btu)	20,988
Idle Energy Rate @ 375°F (Btu/h)	17,449
Heavy-Load Cooking-Energy Efficiency (%)	34.1 ± 1.2
Medium-Load Cooking-Energy Efficiency (%)	23.7 ± 1.8
Light-Load Cooking-Energy Efficiency (%)	13.3 ± 0.7
Production Capacity (lb/h) ^c	33.2 ± 0.2
Cooking Surface Recovery Time (min) ^c	2.42

^a Temperature uniformity reflects the absolute temperature variance across the cooking surface to within 1 inch from each edge.

^b Area that is between 360°F and 390°F.

^c Based on the heavy-load cooking test with a minimum 30-second preparation time between loads.

The US Range RG TSA 2636-1 gas griddle incorporates a simple, solid and easy to clean design into a daily work horse. Food service operators can expect a swift 15.6 minute preheat to 375°F from the US Range griddle and a competitive idle rate of 17,449 with a duty cycle of 24%. Temperature uniformity across the griddle-cooking surface was good with a range of 78°F and a useable cooking surface area of 541 in².

The gas griddle demonstrated competitive cooking-energy efficiencies while being tested at the Food Service Technology Center. The griddle exhibited a heavy-load cooking-energy efficiency of 34% and a production capacity of 33 lb/h. Most food service operations cook under less than full-load scenarios with medium- and light-loads being more representative of real world opera-

Executive Summary

tions. The US Range posted respectable medium and light-load cooking energy efficiencies, 24% and 13% respectively.

The test results can be used to estimate the annual energy consumption for the griddle in a real-world operation. A simple cost model was developed to calculate the relationship between the various cost components (e.g., preheat, idle and cooking costs) and the annual operating cost, using the ASTM test data. For the calculations shown in Table ES-2, the griddle was used to cook 100 pounds of hamburger patties over a 12-hour day, with one preheat per day, 365 days per year.

The US Range gas griddle with its solid construction and competitive performance will provide a food service operator with a dependable and easy to clean appliance.

Table ES-2. Estimated Griddle Energy Consumption and Cost.

Preheat Energy (kBtu/day)	21.0
Idle Energy (kBtu/day)	78.9
Cooking Energy (kBtu/day)	223.1
Annual Energy (kBtu/year)^a	117,873
Annual Cost (\$/year)^b	707

^a 1kBtu = 1,000 Btu

^b Griddle energy costs are based on \$0.60/therm for gas appliances (1 therm = 100,000 Btu)

1 Introduction

Background

Griddles are used throughout the hospitality industry from their first order of bacon at breakfast to the last seared steak at dinner. The griddle is a work-horse that usually occupies a central position on the short order line. Its versatility ranges from crisping and browning, for foods like hash brown potatoes, bacon and pancakes, to searing, for foods like hamburgers, chicken, steak and fish, and to warming or toasting, for bread and buns. For a high production restaurant, the temperature uniformity of the griddle surface is important to assure that the food is evenly cooked.

Dedicated to the advancement of the food service industry, the Food Service Technology Center (FSTC) has focused on the development of standard test methods for commercial food service equipment since 1987. The primary component of the FSTC is a 10,000 square-foot appliance laboratory equipped with energy monitoring and data acquisition hardware, 60 linear feet of canopy exhaust hoods integrated with utility distribution systems, appliance setup and storage areas, and a state-of-the-art demonstration and training facility.

The test methods, approved and ratified by the American Society for Testing and Materials (ASTM), allow benchmarking of equipment such that users can make meaningful comparisons among available equipment choices. By collaborating with the Electric Power Research Institute (EPRI) and the Gas Technology Institute (GTI) through matching funding agreements, the test methods have remained unbiased to fuel choice. End-use customers and commercial appliance manufacturers consider the FSTC to be the national leader in commercial food service equipment testing and standards, sparking alliances with several major chain customers to date.

Since the development of the ASTM test method for griddles in 1989, the FSTC has tested a wide range of gas and electric griddles.²⁻¹³

Introduction

The US Range RG TSA 2636-1 gas griddle features stainless steel construction, 110V snap-action thermostats, a 1-inch thick brushed steel griddle-cooking surface, front mounted grease trough, and removable grease pan. The US Range gas griddle was tested according to the ASTM procedure, and this report documents the results.

The glossary in Appendix A is provided so that the reader has a quick reference to the terms used in this report.

Objectives

The objective of this report is to examine the operation and performance of the US Range gas griddle, model RG TSA 2636-1, under the controlled conditions of the ASTM standard test method. The scope of this testing is as follows:

1. Verify that the appliance is operating at the manufacturer's rated energy input.
2. Document the temperature uniformity of the cooking surface and the accuracy of the thermostats.
3. Determine the time and energy required to preheat the cooking surface from room temperature to 375°F.
4. Characterize the idle energy use with the thermostats set at a calibrated 375°F.
5. Document the cooking energy consumption and efficiency under three hamburger loading scenarios: heavy (24 patties), medium (12 patties), and light (4 patties).
6. Determine the production capacity and cooking surface temperature recovery time during the heavy-load test.
7. Estimate the annual operating cost for the griddle using a standard cost model.

Appliance Description

US Range's RG TSA 2636-1 gas griddle features three U-shaped atmospheric burners – one for every twelve inches of griddle surface. One 110V snap-action thermostat controls each burner with a cooking temperature range be-

Introduction

tween 100°F to 450°F (Figure 1-1). The cooking surface is 1-inch thick steel surrounded by stainless steel front sides and landing ledge as well as 14 gauge side splashguards and back splash. The griddle sits on four adjustable legs.

Appliance specifications are listed in Table 1-1, and the manufacturer's literature is in Appendix B.



Figure 1-1.
US Range RG TSA 2636-1
gas griddle.

Table 1-1. Appliance Specifications.

Manufacturer	US Range
Model	RG TSA 2636-1
Generic Appliance Type	Counter Top Thermostatically Controlled Griddle
Rated Input	72,000 Btu/h
Dimensions	36.0" x 32 1/4" x 17 1/4"
Construction	1 inch-thick brushed steel cooking surface, stainless steel front, side and landing ledge. Side and back splashguards are made from 14-gauge steel.
Controls	Individual 110V snap-action thermostats for each 1-foot cooking zone adjustable from 100 to 450°F.

2 Methods

Setup and Instrumentation

FSTC researchers installed the griddle on a table over a tiled floor under a 4-foot-deep canopy hood that was installed at a height of 6 feet, 6 inches above the floor. The exhaust rate was set to a nominal rate of 300 cfm per linear foot of hood. The griddle was installed with at least 6 inches of clearance between the vertical plane of the griddle and the edge of the hood. All test apparatus were installed in accordance with Section 9 of the ASTM test method.¹

Researchers instrumented the griddle with thermocouples to measure cooking surface temperatures. For the temperature uniformity test, 63 thermocouples were welded to the cooking surface in a grid pattern (see Figure 2-1). Three thermocouples (one at the center of each linear foot of griddle plate (Figure 2-2) were used for the remainder of the tests.

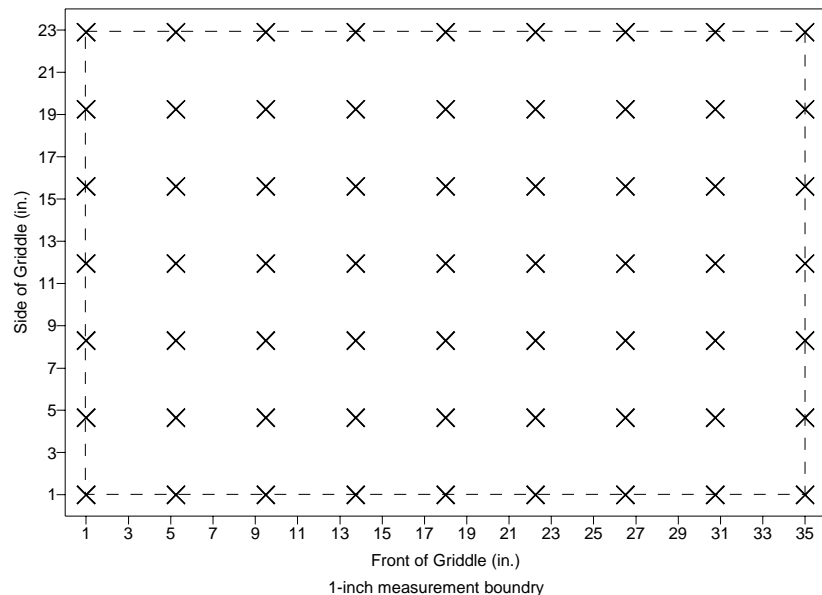

Figure 2-1.
Thermocouple grid for
temperature uniformity
test.

Methods

Natural gas consumption was measured using a positive displacement-type gas meter that generated a pulse every 0.1 ft³. The gas meter and the thermocouples were connected to an automated data acquisition unit that recorded data every 5 seconds. A chemical laboratory used a gas chromatograph to determine the gas heating value on each day of testing. All gas measurements were corrected to standard conditions.

Measured Energy Input Rate

Rated energy input rate is the maximum or peak rate at which the griddle consumes energy—as specified on the griddle’s nameplate. Measured energy input rate is the maximum or peak rate of energy consumption, which is recorded during a period when the burners are operating on full (such as pre-heat). Researchers compared the measured energy input rate with the nameplate energy input rate to ensure that the griddle was operating properly.

Cooking Tests

Researchers specified frozen, 20% fat, quarter-pound hamburger patties for all cooking tests. Each load of hamburgers was cooked to a 35% weight loss. The cooking tests involved “barreling” six loads of frozen hamburger patties; cooking surface temperature was used as a basis for recovery (see Figure 2-2). Each test was followed by a 1-hour wait period and was then repeated two more times. Researchers tested the griddle using 24 patty (heavy) loads, 12 patty (medium) loads, and 4 patty (light) loads.

Due to the logistics involved in removing one load of cooked hamburgers and placing another load onto the griddle, a minimum preparation time of 30 seconds (based on 10 seconds per linear foot) was incorporated into the cooking procedure. This ensures that the cooking tests are uniformly applied from laboratory to laboratory. Griddle recovery was then based on the cooking surface reaching a threshold temperature of 350°F (measured at the center of each linear foot of griddle plate). Reloading within 25°F of the 375°F thermostat set point does not significantly lower the average cooking surface over the cooking cycle, nor does it extend the cook time. The griddle was re-

Methods

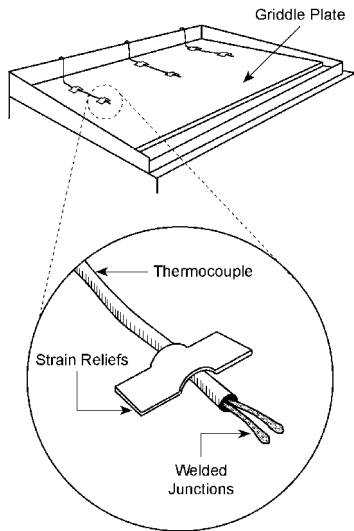

Figure 2-2.
Thermocouple place-
ment for testing.

loaded either after all three thermocouples reached the threshold temperature, or 30 seconds after removing the previous load from the griddle, whichever was longer.

Prior to the six-load test, one to two loads of hamburgers were cooked to stabilize the griddle response. Energy consumption, elapsed time, and the average weight loss of the hamburger patties were recorded during the final six loads of the cooking test. After removing the last load and allowing the griddle to recover, researchers terminated the test.

Each cooking test scenario (heavy-, medium-, and light-) was repeated a minimum of three times to ensure that the reported cooking-energy efficiency and production capacity results had an uncertainty of less than $\pm 10\%$. The results from each test run were averaged, and the absolute uncertainty was calculated based on the standard deviation of the results.

The ASTM results reporting sheets appear in Appendix C.

3 Results

Energy Input Rate

Prior to testing, the energy input rate was measured and compared with the manufacturer's nameplate value. This procedure ensured that the griddle was operating within its specified parameters. The measured energy input rate was 71,622 Btu/h (a difference of 0.53% from the nameplate rating).

Temperature Uniformity

Thermocouples were welded to the cooking surface at the center of each linear foot to facilitate temperature calibration. The thermostat control was turned to a $\sim 375^{\circ}\text{F}$ setting. The thermocouples were then monitored after the griddle had stabilized at the set temperature for one hour. Researchers manually adjusted the control to maintain an average of $375 \pm 5^{\circ}\text{F}$ on the cooking surface at the center of each linear foot. To characterize the temperature profile of the cooking surface at 375°F , researchers welded additional thermocouples to the cooking surface in a 63-point grid with approximately 4 inches between adjacent points. Griddle temperatures were monitored for one hour after the cooking surface had stabilized at a calibrated 375°F . Figure 3-1 illustrates the temperatures across the griddle-cooking surface. The temperature uniformity profiles are represented Figure 3-2. The results from these temperature uniformity tests are summarized in Table 3-1.

Results

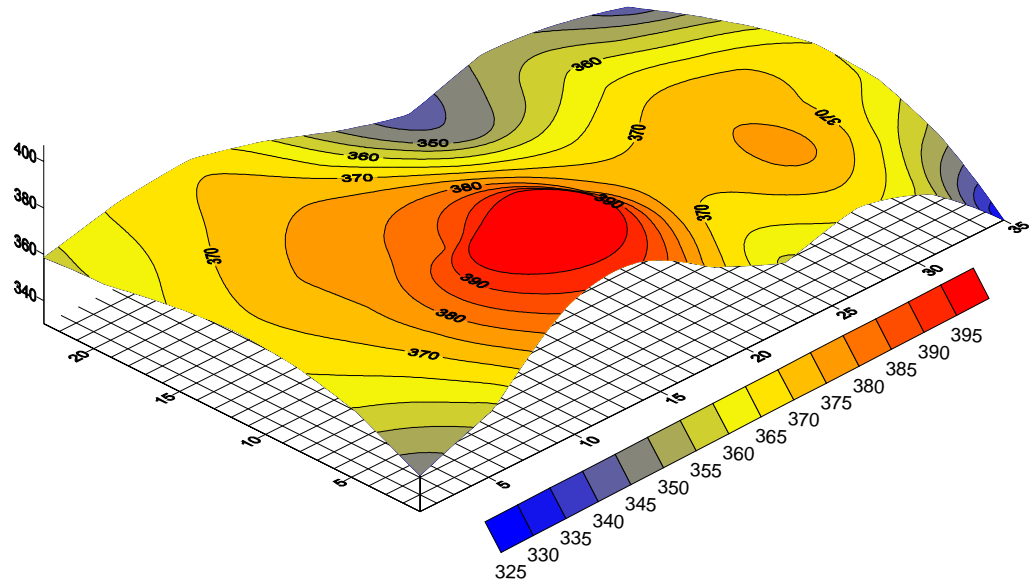

Table 3-1. Temperature Uniformity and Thermostat Accuracy ^a.

Thermostat Setting (°F)	375
Average Surface Temperature (°F)	367
Left Thermostat (°F)	375
Center Thermostat (°F)	373
Right Thermostat (°F)	372
Maximum Temperature Difference Across Plate (°F) ^b	77.6
Useable Cooking Surface (in ²) ^c	541
Standard Deviation of Surface Temperatures (°F)	14.1

^a Thermostat accuracy is the thermostat setting required to maintain 375 ± 5°F on the cooking surface.

^b Maximum temperature difference to within 1-inch of the edge of the griddle plate.

^c Area that is between 360°F and 390°F.

Results

Preheat and Idle Tests

Preheat Energy and Time

Researchers removed the additional thermocouples, leaving only the points at the center of each linear foot. The cooking surface temperature was an average of 74°F at the outset of the preheat test. Researchers measured the energy consumption and time required to preheat the cooking surface to a calibrated 375°F. The time necessary to bring the griddle surface to a temperature of 375°F was 15.6 minutes, during which the griddle consumed 20,988 Btu. Figure 3-3 shows the energy consumption rate in conjunction with the cooking surface temperature during the preheat test.

Idle Energy Rate

The griddle was allowed to stabilize at 375°F for one hour. Researchers then monitored the energy consumption over a 2-hour period. The idle energy rate during this period was 17,449 Btu/h.

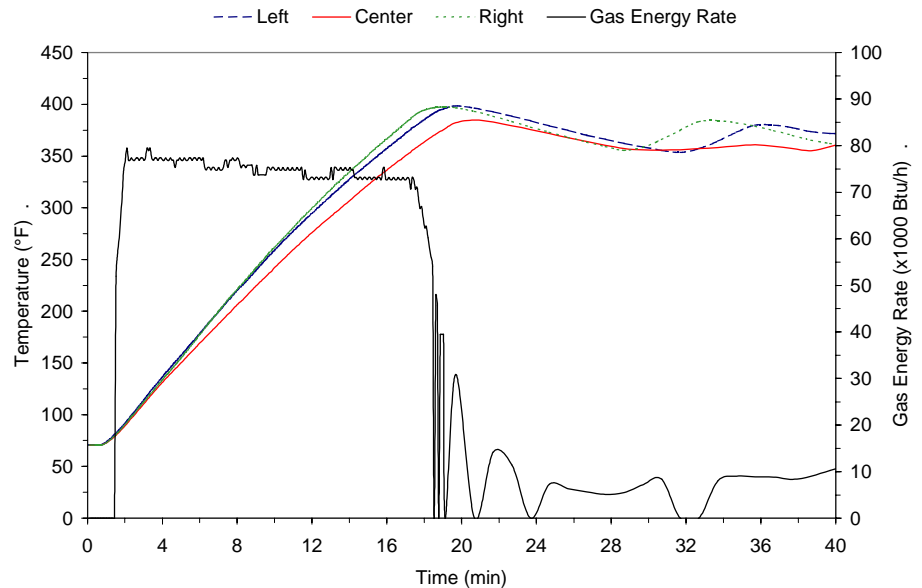

Figure 3-3.
Preheat characteristics.

Results

Test Results

Input, preheat, and idle test results are summarized in Table 3-2.

Table 3-2. Input, Preheat, and Idle Test Results.

Rated Energy Input Rate (Btu/h)	72,000
Measured Energy Input Rate (Btu/h)	71,622
Percentage Difference (%)	0.53
Preheat	
Time to 375°F (min)	15.6
Energy (Btu)	20,988
Rate to 375°F (°F/min)	16.4
Idle Energy Rate @ 375°F (Btu/h)	17,449

Cooking Tests

The griddle was tested under three loading scenarios: heavy (24 hamburger patties), medium (12 hamburger patties), and light (4 hamburger patties). The hamburgers used for the cooking tests consisted of 20% fat and approximately 60% moisture, as specified by the ASTM procedure. Researchers monitored hamburger patty cook time and weight loss, cooking surface recovery time, and griddle energy consumption during these tests.

Heavy-Load Tests

The heavy-load cooking tests were designed to reflect a griddle's maximum performance. The griddle is used to cook six loads of 24 frozen hamburger patties—one load after the other, similar to a batch-cooking procedure. Figure 3-4 shows the average cooking surface temperature during a heavy-load test. One load was used to stabilize the griddle, and six loads were used to calculate cooking-energy efficiency and production capacity.

Results

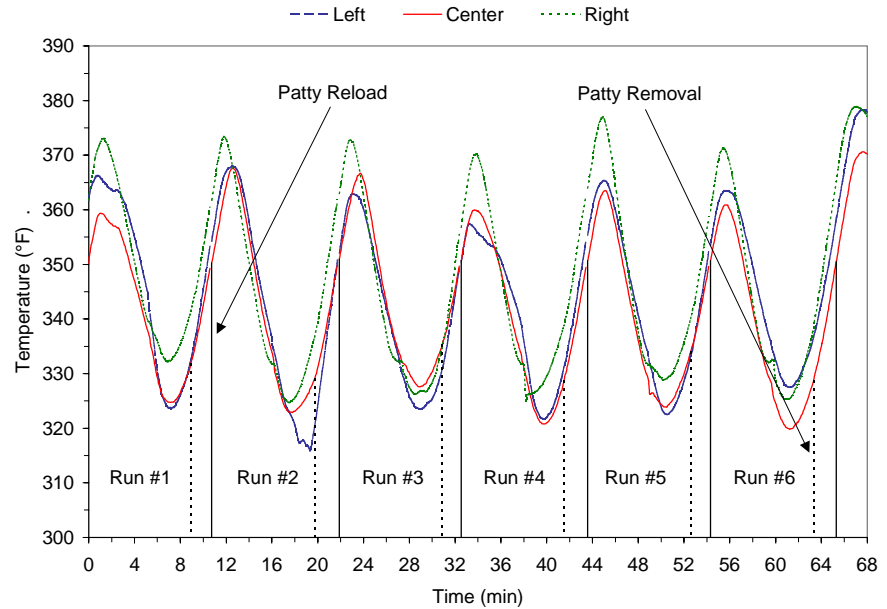

*Figure 3-4.
Average heavy-load
cooking surface
temperatures.*

Figure 3-5 illustrates the griddle's temperature response while a heavy load of frozen hamburger patties was cooked. Production capacity includes the time required for the cooking surface to recover to 350°F (recovery time).

Medium- and Light-Load Tests

Medium- and light-load tests represent a more typical usage pattern for a griddle in cook-to-order applications. Since a griddle is seldom fully loaded in many food service establishments, these part-load efficiencies can be used to estimate griddle performance in an actual operation. Both the medium- and light-load tests were conducted on the left half of the cooking surface. Since the entire griddle was heated to 375°F, the energy consumed during these part-load tests includes radiant heat losses from the unused half of the griddle.

Results

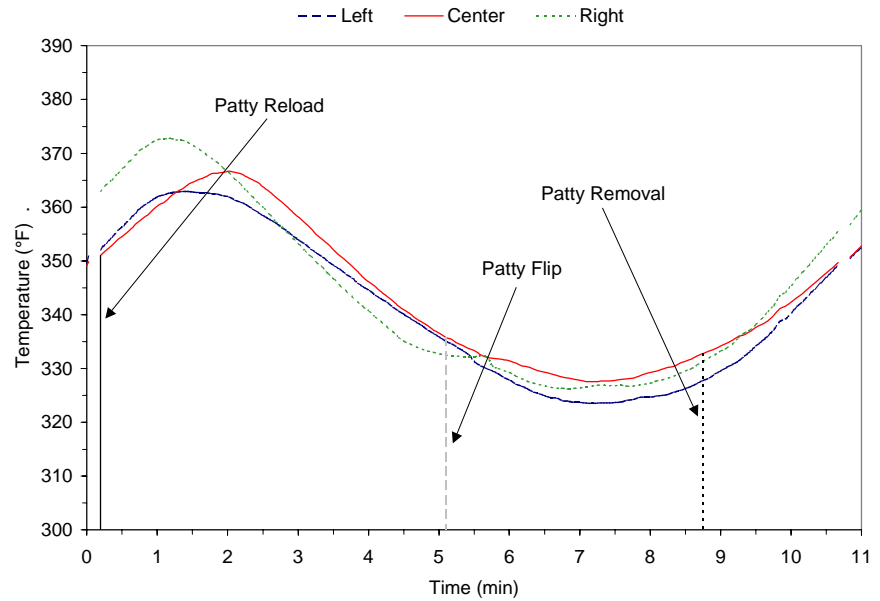

*Figure 3-5.
Griddle temperature
signature while cooking a
heavy-load of hamburgers.*

Test Results

Energy imparted to the hamburger patties was calculated by separating the various components of the patties (water, fat, and solids) and determining the amount of heat gained by each component (Appendix D). The griddle's cooking-energy efficiency for a given loading scenario is the amount of energy imparted to the hamburger patties, expressed as a percentage of the amount of energy consumed by the griddle during the cooking process.

Cooking-energy efficiency results for the heavy-load tests were 34.4%, 34.3%, and 33.5%, yielding a maximum uncertainty of 1.17% in the test results. Table 3-3 summarizes the results of the ASTM cooking-energy efficiency and production capacity tests.

Results

Table 3-3. Cooking-Energy Efficiency and Production Capacity Test Results.

	Heavy-Load	Medium-Load	Light-Load
Hamburger Cook Time (min)	8.47	8.26	8.50
Average Recovery Time (min)	2.42	2.81	< 1.0
Production Rate (lb/h)	33.2 ± 0.5	16.2 ± 1.1	6.9 ± 0.1
Energy Consumption (Btu/lb)	1,383	2,063	3,618
Cooking Energy Rate (Btu/h)	45,869	33,289	24,792
Cooking-Energy Efficiency (%)	34.1 ± 1.2	23.7 ± 1.8	13.3 ± 0.7

Figure 3-6 illustrates the relationship between cooking-energy efficiency and production rate for this griddle. Griddle production rate is a function of both the hamburger patty cook time and the recovery time. Appendix D contains a synopsis of test data for each replicate of the cooking tests.

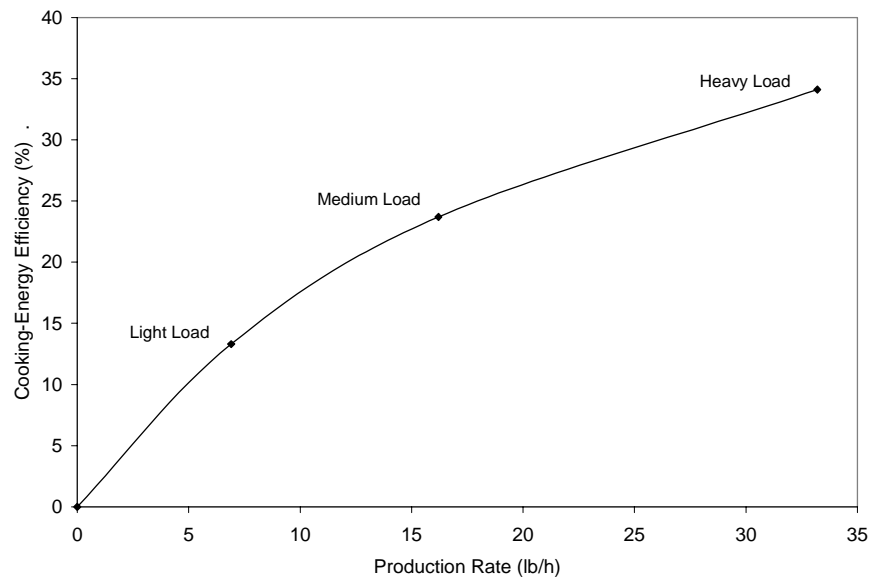

*Figure 3-6.
Griddle part-load cooking-energy efficiency.*

Note: Light-load = 4 hamburgers/load; medium-load = 12 hamburgers/load; heavy-load = 24 hamburgers/load

Results

Figure 3-7 illustrates the relationship between the griddle's average energy consumption rate and the production rate. This graph can be used as a tool to estimate the average energy rate for different types of operations. Average energy consumption rates at 10, 20, and 30 pounds per hour are 26,930 Btu/h, 35,390 Btu/h, and 43,850 Btu/h, respectively.

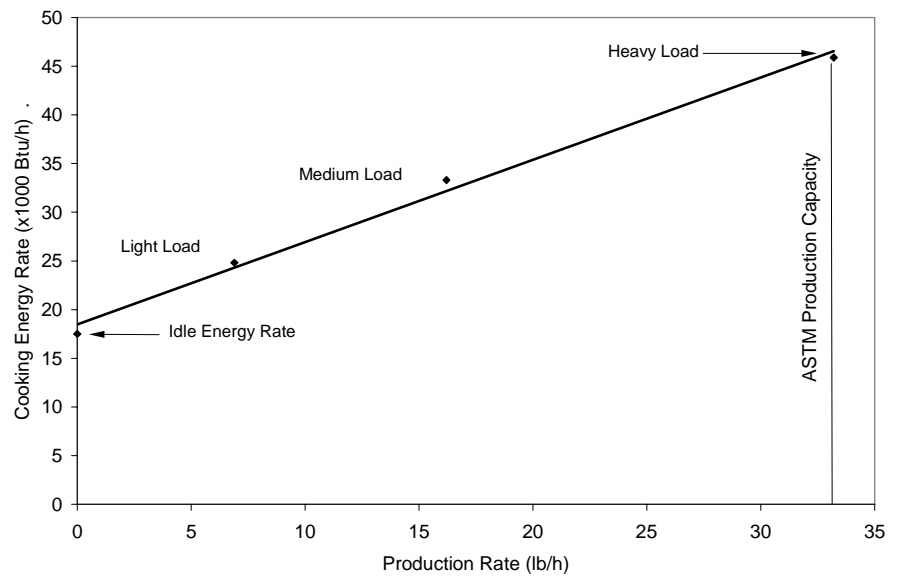

Figure 3-7.
Griddle cooking energy consumption profile.

Note: Light-load = 4 hamburgers/load; medium-load = 12 hamburgers/load; heavy-load = 24 hamburgers/load

Energy Cost Model

The test results can be used to estimate the annual energy consumption for the griddle in a real-world operation. A simple cost model was developed to calculate the relationship between the various cost components (e.g., preheat, idle and cooking costs) and the annual operating cost (Appendix E), using the ASTM test data. For this model, the griddle was used to cook 100 pounds of hamburger patties over a 12-hour day, with one preheat per day, 365 days per year. The idle (standby) time for the griddle was determined by taking the difference between the total daily on-time (12 hours) and the time spent cook-

Results

ing and preheating. This approach produces a more accurate estimate of the operating costs for the griddle. Table 3-4 summarizes the annual energy consumption and associated energy cost for the griddle under this scenario.

Table 3-4. Estimated Griddle Energy Consumption and Cost.

Preheat Energy (kBtu/day)	21.0
Idle Energy (kBtu/day)	78.9
Cooking Energy (kBtu/day)	223.1
Annual Energy (kBtu/year)^a	117,873
Annual Cost (\$/year)^b	707

^a 1kBtu = 1,000 Btu

^b Griddle energy costs are based on \$0.60/therm for gas appliances (1 therm = 100,000 Btu)

4 Conclusions

The US Range RG TSA 2636-1 gas griddle was successfully tested in accordance with ASTM standard test method, exhibiting performance that compares favorably with other griddles in its class. The RG TSA 2636-1 griddle demonstrated a swift preheat of 15.6 minutes and a competitive idle rate of 17,449 Btu/h. A good temperature uniformity with 541 in² of usable cooking surface enables a food service operator to cook anywhere on the griddle surface without sacrificing product quality.

During heavy-load testing, the RG TSA 2636-1 griddle posted a respectable cooking-energy efficiency of 34% while running at a 63% duty cycle. The extra power reserved during cooking suggests that a more responsive control to temperature changes on the griddle-cooking surface would dramatically improve its 33 lb/h production capacity.

The US Range griddle demonstrated economical part-load cooking energy efficiencies (23.7% and 13.3%) during the medium and light-load tests. Since food service operations typically cook under less than full-load scenarios. The medium and light-load test results represent more of real world application. The US Range RG TSA 2636-1 gas griddle incorporates a solid construction with easy cleaning and worthy performance characteristics.

The cost model estimates showed that the US Range griddle, when used to cook 100 pounds of hamburgers a day, 365 days a year, would consume 117,873 kBtu of energy. Assuming an energy cost of 60 cents per therm, 117,873 kBtu (1,179 therms) translates to an annual operating cost of 707 dollars.

5 References

1. American Society for Testing and Materials, 1999. *Standard Test Method for the Performance of Griddles*. ASTM Designation F 1275-99. In Annual Book of ASTM Standards, West Conshohocken, PA.
2. Pacific Gas and Electric Company. 1989. *Development and Application of a Uniform Testing Procedure for Griddles*. Report 008.1-89.2 prepared for Research and Development. San Ramon, California: Pacific Gas and Electric Company.
3. Zabrowski, D., Nickel, J., 1993. *U.S. Range Model RGTA-2436-1 Gas Griddle Application of ASTM Standard Test Method*. Food Service Technology Center Report 5017.93.1, September.
4. Zabrowski D., Nickel, J., 1993. *Keating MIRACLEAN Model 36 x 30 IBLD Gas Griddle: Application of ASTM Standard Test Method F 1275-90*. Food Service Technology Center Report 5017.93.3, September.
5. Zabrowski, D., Mogel, K., Weller, T., 1996. *Toastmaster® Accu-Miser™, Model AM36SS Electric Griddle Performance Test*. Food Service Technology Center Report 5011.96.34, January.
6. Zabrowski, D., Cadotte, R., Sorensen, G., 1998. *AccuTemp, Model 2-3-14-208 Electric Griddle Performance Test*. Food Service Technology Center Report 5011.98.55, February.
7. Zabrowski, D., Schmitz, M., Sorensen, G., 1999. *Taylor, Model QS24-23 Electric Double-Sided Griddle Performance Test*. Food Service Technology Center Report 5011.99.69, January.
8. Cowen, D., Zabrowski, D., Miner, S., 2001. *Anets GoldenGRILL™ Gas Griddle Performance Test*. Food Service Technology Center Report 5011.01.04, December.

Results

9. Cowen, D., Zabrowski, D., Miner, S., 2002. *AccuTemp Gas Griddle Performance Test: Application of ASTM Standard Test Method F1275-99*. Food Service Technology Center Report 5011.02.04, January.
10. Cowen, D., Zabrowski, D., 2002. *Garland Gas Griddle Performance Test: Application of ASTM Standard Test Method F1275-99*. Food Service Technology Center Report 5011.02.05, December.
11. Cowen, D., Zabrowski, D., 2003. *Wells Gas Griddle Performance Tests: Application of ASTM Standard Test Method F1275-99*. Food Service Technology Center Report 5011.03.05, January.
12. Cowen, D., Zabrowski, D., 2003. *Imperial Gas Griddle Performance Tests: Application of ASTM Standard Test Method F1275-99*. Food Service Technology Center Report 5011.03.06, January.
13. Cowen, D., Zabrowski, D., 2003. *Jade JGTSD Gas Griddle Performance Tests: Application of ASTM Standard Test Method F1275-99*. Food Service Technology Center Report 5011.03.18, May.

A Glossary

Cooking Energy (kWh or kBtu)

The total energy consumed by an appliance as it is used to cook a specified food product.

Cooking Energy Consumption Rate (kW or kBtu/h)

The average rate of energy consumption during the cooking period.

Cooking-Energy Efficiency (%)

The quantity of energy input to the food products; expressed as a percentage of the quantity of energy input to the appliance during the heavy-, medium-, and light-load tests.

Duty Cycle (%)

Load Factor

The average energy consumption rate (based on a specified operating period for the appliance) expressed as a percentage of the measured energy input rate.

$$\text{Duty Cycle} = \frac{\text{Average Energy Consumption Rate}}{\text{Measured Energy Input Rate}} \times 100$$

Energy Input Rate (kW or kBtu/h)

Energy Consumption Rate
Energy Rate

The peak rate at which an appliance will consume energy, typically reflected during pre-heat.

Heating Value (Btu/ft³)

Heating Content

The quantity of heat (energy) generated by the combustion of fuel. For natural gas, this quantity varies depending on the constituents of the gas.

Idle Energy Rate (kW or Btu/h)

Idle Energy Input Rate
Idle Rate

The rate of appliance energy consumption while it is “holding” or maintaining a stabilized operating condition or temperature.

Idle Temperature (°F, Setting)

The temperature of the cooking cavity/surface (selected by the appliance operator or specified for a controlled test) that is maintained by the appliance under an idle condition.

Idle Duty Cycle (%)

Idle Energy Factor

The idle energy consumption rate expressed as a percentage of the measured energy input rate.

$$\text{Idle Duty Cycle} = \frac{\text{Idle Energy Consumption Rate}}{\text{Measured Energy Input Rate}} \times 100$$

Glossary

Measured Input Rate (kW or Btu/h)

Measured Energy Input Rate
Measured Peak Energy Input Rate

The maximum or peak rate at which an appliance consumes energy, typically reflected during appliance preheat (i.e., the period of operation when all burners or elements are “on”).

Pilot Energy Rate (kBtu/h)

Pilot Energy Consumption Rate

The rate of energy consumption by the standing or constant pilot while the appliance is not being operated (i.e., when the thermostats or control knobs have been turned off by the food service operator).

Preheat Energy (kWh or Btu)

Preheat Energy Consumption

The total amount of energy consumed by an appliance during the preheat period.

Preheat Rate (°F/min)

The rate at which the cook zone heats during a preheat.

Preheat Time (minute)

Preheat Period

The time required for an appliance to “heat up” from the ambient room temperature ($75 \pm 5^\circ\text{F}$) to a specified (and calibrated) operating temperature or thermostat set point.

Production Capacity (lb/h)

The maximum production rate of an appliance while cooking a specified food product in accordance with the heavy-load cooking test.

Production Rate (lb/h)

Productivity

The average rate at which an appliance brings a specified food product to a specified “cooked” condition.

Rated Energy Input Rate

(kW, W or Btu/h, Btu/h)
Input Rating (ANSI definition)
Nameplate Energy Input Rate
Rated Input

The maximum or peak rate at which an appliance consumes energy as rated by the manufacturer and specified on the nameplate.

Recovery Time (minute, second)

The average time from the removal of the cooked hamburger patties from the griddle cooking surface until the cooking surface is within 25°F of the thermostat set point and then griddle is ready to be reloaded.

Test Method

A definitive procedure for the identification, measurement, and evaluation of one or more qualities, characteristics, or properties of a material, product, system, or service that produces a test result.

Typical Day

A sampled day of average appliance usage based on observations and/or operator interviews, used to develop an energy cost model for the appliance.

B Appliance Specifications

Appendix B includes the product literature for the US Range griddle.

Appliance Specifications

Manufacturer	US Range
Model	RG TSA 2636-1
Generic Appliance Type	Counter Top Thermostatically Controlled Griddle
Rated Input	72,000 Btu/h
Dimensions	36.0" x 32 1/4" x 17 1/4"
Construction	1 inch-thick brushed steel cooking surface, stainless steel front, side and landing ledge. Side and back splashguards are made from 14-gauge steel.
Controls	Individual 110V snap-action thermostats for each 1-foot cooking zone adjustable from 100 to 450°F.



Item #: _____

Model #:

Product Name: Regal Series Snap Action
Thermostat Control Griddle

U.S. Range

Regal Series Snap Action Thermostat Control Griddle

Model #RGSTSA



RGTSA-2448-1

Short Form Specifications

Shall be U.S. Range Regal Snap Thermostat Control Griddle. Model _____ with a total BTU/HR rating of _____ when used with natural or propane gas. Finish is to be stainless steel front and sides.

Standard Features

- Stainless Steel Front, Sides and Landing Ledge
- 24" - 72" wide
- 14 Gauge Splash Guard
- Built-In Front Grease Trough
- Large Capacity, Removable Grease Container
- Aluminized Steel Burners, One Every 12"
- 24,000 BTU/HR Per Burner
- Snap Action Thermostat Control (110 volt)
- 1" Thick Steel Griddle Plate
- 4" Legs with Adjustable Feet
- 3/4" Rear Gas Connection
- 3/4" Gas Regulator
- One Year Parts and Labor Warranty

Optional Features

- Stainless Steel Equipment Stand with Intermediate Shelf
- Black Painted Equipment Stand with Intermediate Shelf
- Swivel Casters on Stand

Type of Gas

- Natural
- Propane
- Elevation above 2,000 ft. – Specify ____ft.



For USA, Contact:
Garland Commercial Industries, INC.
Tel: 570-636-1000
Fax: 570-636-3903

For United Kingdom & Ireland, Contact::
Enodis
Tel: 0181-561-0433
Fax: 0181-848-0041

For Canada & the Rest of the World, Contact:
Garland Commercial Ranges, Ltd.
Tel: 905-624-0260
Fax: 905-624-5669



Item #: _____

Model #:

Product Name: Regal Series Snap Action
Thermostat Control Griddle

Model No.	Width	Depth	Height	No. of Burners	Total BTU	Griddle Size	Shipping Information		
					Natural Propane Gas	WxD	Lbs.	Kg	Cube
RGTSA-2424-1	24"	30 1/4"	16 3/4"	2	48,000	24"x22"	270	122	18.0
RGTSA-2436-1	36"	30 1/4"	16 3/4"	3	72,000	36"x22"	370	168	25.0
RGTSA-2448-1	48"	30 1/4"	16 3/4"	4	96,000	48"x22"	441	200	33.0
RGTSA-2460-1	60"	30 1/4"	16 3/4"	5	120,000	60"x22"	578	262	40.0
RGTSA-2472-1	72"	30 1/4"	16 3/4"	6	144,000	72"x22"	800	363	47.0

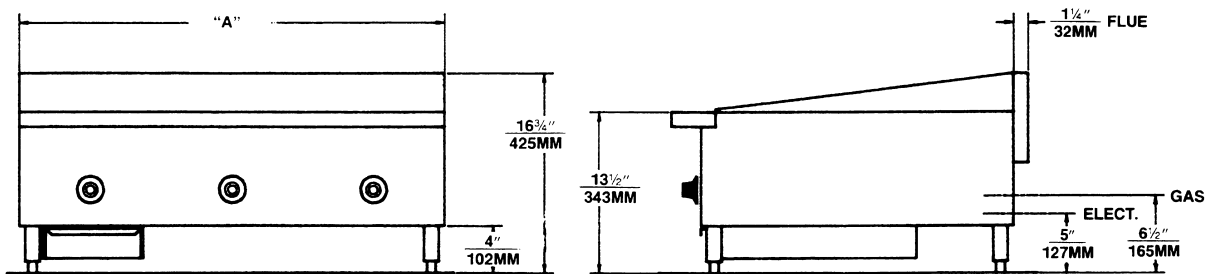
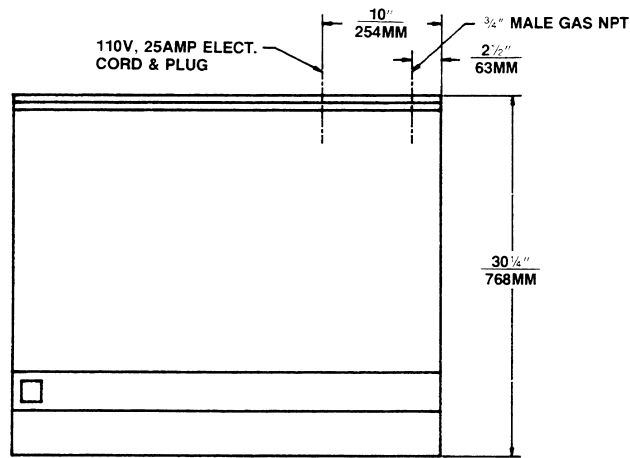

NOTE:

- Many local codes exist, and it is the responsibility of the Owner and Installer to comply with those codes.
- U.S. Range reserves the right to change or improve our specifications without notification.
- These appliances are intended for commercial use by professionally trained personnel.

C Results Reporting Sheets

Manufacturer: US Range

Model: RG TSA 2636-1

Date: August 2003

Test Griddle

Description of operational characteristics: 1-inch thick steel plate with stainless steel construction on the sides, landing ledge and front. Three 24,000 Btu/h aluminized steel burners are individually controlled by 110V snap-action thermostats. The griddle features four adjustable legs and a built in grease trough with a large-capacity, removable grease container.

Apparatus

√ Check if testing apparatus conformed to specifications in section 6.

Deviations: The griddle temperature uniformity plot was increased in size to characterize temperatures to within 1-inch of the outside edge of the griddle plate. Also, surface temperature recovery during the cooking tests was lowered from 365°F to 350°F per an upcoming revision of the ASTM griddle test method.

Energy Input Rate

Heating Value (Btu/scf)	1015
Rated (Btu/h)	72,000
Measured (Btu/h)	71,622
Percent Difference between Measured and Rated (%)	0.53

Results Reporting Sheets

Temperature Uniformity and Thermostat Accuracy^a

Left Thermostat (°F)	375
Center Thermostat (°F)	376
Right Thermostat (°F)	376
Maximum Temperature Difference (°F) ^b	50.0
Useable Cooking Surface (in ²) ^c	451

^a Thermostat settings required to maintain 375°F cooking surface temperature

^b Maximum temperature difference to within 1-inch of the edge of the griddle plate.

^c Area that is between 360°F and 390 °F.

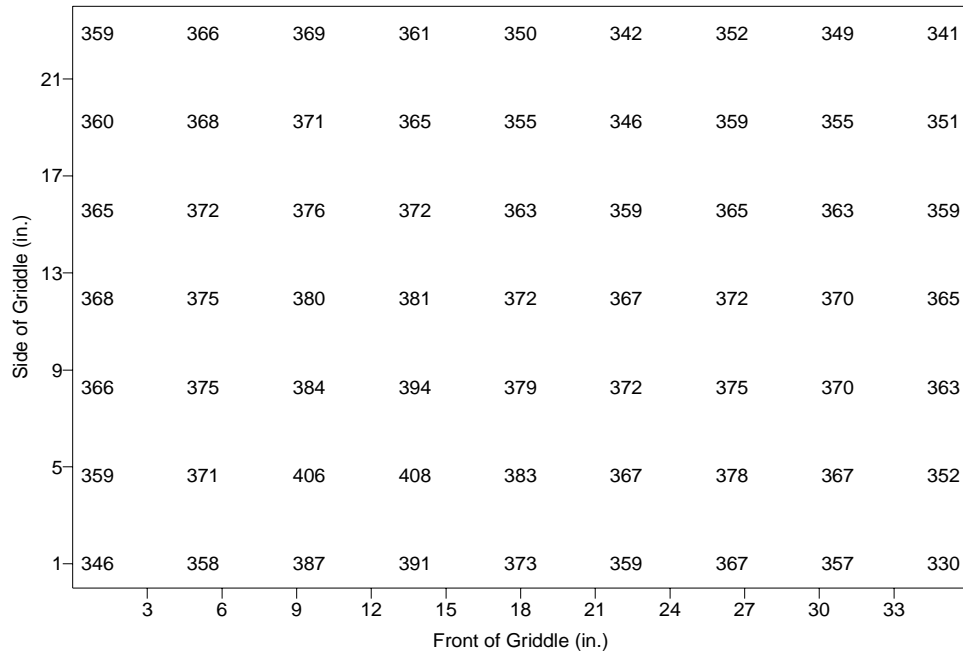

Figure C-1. Average cooking surface temperatures.

Results Reporting Sheets

Preheat Energy and Time

Heating Value (Btu/scf)	1015
Starting Temperature (°F)	71.0
Energy Consumption (Btu)	20,988
Duration (min)	15.6
Preheat Rate (°F/min)	16.4

Idle Energy Rate

Heating Value (Btu/scf)	1015
Idle Energy Rate @ 375°F (Btu/h)	17,449

Heavy-Load Cooking-Energy Efficiency Test Results

Heating Value (Btu/scf)	1015
Cooking Time (min)	8.47
Average Cooking Surface Recovery Time (min)	2.42
Production Capacity (lb/h)	33.2 ± 0.2
Energy to Food (Btu/lb)	471
Cooking Energy Rate (Btu/h)	45,869
Energy per Pound of Food Cooked (Btu/lb)	1,383
Cooking-Energy Efficiency (%)	34.1 ± 1.2

Results Reporting Sheets

Medium-Load Cooking-Energy Efficiency Test Results

Heating Value (Btu/scf)	1019
Cooking Time (min)	8.26
Average Cooking Surface Recovery Time (min)	2.81
Production Rate (lb/h)	16.2 ± 1.1
Energy to Food (Btu/lb)	489
Cooking Energy Rate (Btu/h)	33,289
Energy per Pound of Food Cooked (Btu/lb)	2,063
Cooking-Energy Efficiency (%)	23.7 ± 1.8

Light-Load Cooking-Energy Efficiency Test Results

Heating Value (Btu/scf)	1016
Cooking Time (min)	8.50
Average Cooking Surface Recovery Time (min)	< 1.0
Production Capacity (lb/h)	6.9 ± 0.1
Energy to Food (Btu/lb)	481
Cooking Energy Rate (Btu/h)	24,792
Energy per Pound of Food Cooked (Btu/lb)	3,618
Cooking-Energy Efficiency (%)	13.3 ± 0.7

D Cooking-Energy Efficiency Data

Table D-1. Specific Heat and Latent Heat

Specific Heat (Btu/lb, °F)	
Ice	0.50
Fat	0.40
Solids	0.20
Latent Heat (Btu/lb)	
Fusion, Water	144
Fusion, Fat	44
Vaporization, Water	970

Cooking-Energy Efficiency Data

Table D-2. Heavy-Load Test Data

	Repetition #1	Repetition #2	Repetition #3
Measured Values			
Total Energy (Btu)	49,245	49,776	50,793
Cook Time (min)	8.40	8.50	8.50
Total Test Time (min)	65.1	65.1	65.8
Weight Loss (%)	34.0	34.1	33.8
Initial Weight (lb)	36.115	36.115	36.115
Final Weight (lb)	23.825	23.812	23.926
Initial Fat Content (%)	18.5	18.5	18.5
Initial Moisture Content (%)	61.5	61.5	61.5
Final Moisture Content (%)	51.9	51.2	51.1
Initial Temperature (°F)	0	0	0
Final Temperature (°F)	160	160	160
Calculated Values			
Initial Weight of Water (lb)	22.529	22.529	22.529
Final Weight of Water (lb)	12.365	12.192	12.226
Weight of Fat (lb)	6.684	6.684	6.684
Weight of Solids (lb)	7.223	7.223	7.223
Sensible to Ice (Btu)	355	355	355
Sensible to Water (Btu)	2,849	2,851	2,833
Sensible to Fat (Btu)	429	429	427
Sensible to Solids (Btu)	232	232	231
Latent - Water Fusion (Btu)	3,198	3,198	3,198
Latent - Fat Fusion (Btu)	303	303	304
Latent - Water Vaporization (Btu)	9,551	9,722	9,685
Total Energy to Food (Btu)	16,917	17,091	17,032
Energy to Food (Btu/lb)	468	473	472
Total Energy to Griddle (Btu)	49,245	49,776	50,793
Energy to Griddle (Btu/lb)	1,364	1,378	1,406
Cooking-Energy Efficiency (%)	34.4	34.3	33.5
Cooking Energy Rate (Btu/h)	45,408	45,891	46,309
Production Rate (lb/h)	33.3	33.3	32.9
Average Recovery Time (min)	2.45	2.35	2.47

Cooking-Energy Efficiency Data

Table D-3. Medium-Load Test Data

	Repetition #1	Repetition #2	Repetition #3	Repetition #4
Measured Values				
Total Energy (Btu)	36,040	35,559	37,861	37,915
Cook Time (min)	8.15	8.14	8.50	8.26
Total Test Time (min)	66.6	63.2	67.5	68.5
Weight Loss (%)	35.0	35.9	35.5	34.1
Initial Weight (lb)	18.000	18.000	17.594	17.897
Final Weight (lb)	11.696	11.544	11.317	11.797
Initial Fat Content (%)	18.5	18.5	18.5	18.5
Initial Moisture Content (%)	61.5	61.5	61.5	61.5
Final Moisture Content (%)	49.6	50.1	49.6	49.8
Initial Temperature (°F)	0	0	0	0
Final Temperature (°F)	163	165	164	160
Calculated Values				
Initial Weight of Water (lb)	11.070	11.070	11.070	11.070
Final Weight of Water (lb)	5.801	5.784	5.613	5.875
Weight of Fat (lb)	3.331	3.331	3.248	3.312
Weight of Solids (lb)	3.600	3.600	3.510	3.579
Sensible to Ice (Btu)	177	177	173	176
Sensible to Water (Btu)	1,449	1,473	1,426	1,414
Sensible to Fat (Btu)	217	220	213	213
Sensible to Solids (Btu)	117	119	115	115
Latent - Water Fusion (Btu)	1,594	1,594	1,554	1,585
Latent - Fat Fusion (Btu)	151	150	147	150
Latent - Water Vaporization (Btu)	5,106	5,132	5,020	4,972
Total Energy to Food (Btu)	8,811	8,865	8,647	8,624
Energy to Food (Btu/lb)	489	493	493	482
Total Energy to Griddle (Btu)	36,040	35,559	37,861	37,915
Energy to Griddle (Btu/lb)	2,002	1,975	2,158	2,118
Cooking-Energy Efficiency (%)	24.4	24.9	22.8	22.7
Cooking Energy Rate (Btu/h)	32,478	33,769	33,679	33,229
Production Rate (lb/h)	16.2	17.1	15.6	15.7
Average Recovery Time (min)	2.94	2.39	2.74	3.15

Cooking-Energy Efficiency Data

Table D-4. Light-Load Test Data

	Repetition #1	Repetition #2	Repetition #3
Measured Values			
Total Energy (Btu)	22,126	21,780	21,224
Cook Time (min)	8.51	8.50	8.50
Total Test Time (min)	52.8	52.3	52.5
Weight Loss (%)	35.2	35.3	34.4
Initial Weight (lb)	6.000	6.000	6.000
Final Weight (lb)	3.886	3.885	3.935
Initial Fat Content (%)	18.2	18.2	18.2
Initial Moisture Content (%)	61.8	61.8	61.8
Final Moisture Content (%)	51.9	51.2	51.1
Initial Temperature (°F)	0	0	0
Final Temperature (°F)	163	163	161
Calculated Values			
Initial Weight of Water (lb)	3.708	3.708	3.708
Final Weight of Water (lb)	2.017	1.989	2.011
Weight of Fat (lb)	1.094	1.094	1.094
Weight of Solids (lb)	1.200	1.200	1.200
Sensible to Ice (Btu)	59	59	59
Sensible to Water (Btu)	487	487	479
Sensible to Fat (Btu)	72	72	71
Sensible to Solids (Btu)	39	39	39
Latent - Water Fusion (Btu)	534	534	534
Latent - Fat Fusion (Btu)	49	49	49
Latent - Water Vaporization (Btu)	1,639	1,667	1,645
Total Energy to Food (Btu)	2,879	2,906	2,875
Energy to Food (Btu/lb)	480	484	479
Total Energy to Griddle (Btu)	22,126	21,780	21,224
Energy to Griddle (Btu/lb)	3,688	3,630	3,537
Cooking-Energy Efficiency (%)	13.0	13.3	13.5
Cooking Energy Rate (Btu/h)	25,125	24,973	24,279
Production Rate (lb/h)	6.8	6.9	6.9
Average Recovery Time (min)	< 1.0	< 1.0	< 1.0

Cooking-Energy Efficiency Data

Table D-6. Cooking-Energy Efficiency and Production Capacity Statistics

	Cooking-Energy Efficiency			Production Capacity
	Heavy-Load	Medium-Load	Light-Load	
Replicate #1	34.4	24.4	13.0	33.3
Replicate #2	34.3	24.9	13.3	33.3
Replicate #3	33.5	22.8	13.5	32.9
Replicate #4	--	22.7	--	--
Average	34.1	23.7	13.3	33.2
Standard Deviation	0.34	1.11	0.27	0.21
Absolute Uncertainty	1.17	1.76	0.67	0.52
Percent Uncertainty	3.43	7.43	5.04	1.57

E Energy Cost Model

Procedure for Calculating the Energy Consumption of a Griddle Based on Reported Test Results

Appliance test results are useful not only for benchmarking appliance performance, but also for estimating appliance energy consumption. The following procedure is a guideline for estimating griddle energy consumption based on data obtained from applying the appropriate test method.

The intent of this Appendix is to present a standard method for estimating griddle energy consumption based on ASTM performance test results. The examples contained herein are for information only and should not be considered an absolute. To obtain an accurate estimate of energy consumption for a particular operation, parameters specific to that operation should be used (e.g., operating time, and amount of food cooked under heavy-, medium-, and light-loads).

The calculation will proceed as follows: First, determine the appliance operating time and total number of preheats. Then estimate the quantity of food cooked and establish the breakdown among heavy- (whole cooking surface loaded with product), medium- (half the cooking surface loaded with product), and light- (single-serving) loads. For example, a griddle operating for 12 hours a day with one preheat cooked 100 pounds of food: 20% of the food was cooked under heavy-load conditions, 60% was cooked under medium-load conditions, and 20% was cooked under light-load conditions. Calculate the energy due to cooking at heavy-, medium-, and light-load cooking rates, and then calculate the idle energy consumption. The total daily energy is the sum of these components plus the preheat energy. For simplicity, it is assumed that subsequent preheats require the same time and energy as the first preheat of the day.

The application of the test method to a gas griddle yielded the following results:

Energy Cost Model

Table E-1: Gas Griddle Test Results.

Test	Result
Preheat Time	15.6 min
Preheat Energy	20,988 Btu
Idle Energy Rate	17,449 Btu/h
Heavy-Load Cooking Energy Rate	45,869 Btu/h
Medium-Load Cooking Energy Rate	33,289 Btu/h
Light-Load Cooking Energy Rate	24,792 Btu/h
Production Capacity	33.2 lb/h
Medium-Load Production Rate	16.2 lb/h
Light-Load Production Rate	6.85 lb/h

Step 1—The following appliance operation is assumed:

Table E-2: Griddle Operation Assumptions.

Operating Time	12 h
Number of Preheats	1 preheat
Total Amount of Food Cooked	100 lb
Percentage of Food Cooked Under Heavy-Load Conditions	20% (× 100 lb = 20 lb)
Percentage of Food Cooked Under Medium-Load Conditions	60% (× 100 lb = 60 lb)
Percentage of Food Cooked Under Light-Load Conditions	20% (× 100 lb = 20 lb)

Step 2—Calculate the total heavy-load energy.

The total time cooking heavy-loads is as follows:

$$t_h = \frac{\%h \times W}{PC},$$

$$t_h = \frac{20\% \times 100 \text{ lb}}{33.2 \text{ lb/h}},$$

$$t_h = 0.60 \text{ h}$$

Energy Cost Model

The total heavy-load energy consumption is then calculated as follows:

$$\begin{aligned}E_{gas,h} &= q_{gas,h} \times t_h \\E_{gas,h} &= 45,869 \text{ Btu/h} \times 0.60 \text{ h} \\E_{gas,h} &= 27,521 \text{ Btu}\end{aligned}$$

Step 3—Calculate the total medium-load energy.

The total time cooking medium-loads is as follows:

$$\begin{aligned}t_m &= \frac{\% m \times W}{PR_m}, \\t_m &= \frac{60\% \times 100 \text{ lb}}{16.2 \text{ lb/h}}, \\t_m &= 3.70 \text{ h}\end{aligned}$$

The total medium-load energy consumption is then calculated as follows:

$$\begin{aligned}E_{gas,m} &= q_{gas,m} \times t_m \\E_{gas,m} &= 33,289 \text{ Btu/h} \times 3.70 \text{ h} \\E_{gas,m} &= 123,169 \text{ Btu}\end{aligned}$$

Step 4—Calculate the total light-load energy.

The total time cooking light-loads is as follows:

$$\begin{aligned}t_l &= \frac{\% l \times W}{PR_l}, \\t_l &= \frac{20\% \times 100 \text{ lb}}{6.85 \text{ lb/h}}, \\t_l &= 2.92 \text{ h}\end{aligned}$$

The total light-load energy consumption is then calculated as follows:

$$\begin{aligned}E_{gas,l} &= q_{gas,l} \times t_l \\E_{gas,l} &= 24,792 \text{ Btu/h} \times 2.92 \text{ h} \\E_{gas,l} &= 72,393 \text{ Btu}\end{aligned}$$

Energy Cost Model

Step 5—Calculate the total idle time and energy consumption.

The total idle time is determined as follows:

$$t_i = t_{on} - t_h - t_m - t_l - \frac{n_p \times t_p}{60},$$

$$t_i = 12.0 \text{ h} - 0.60 \text{ h} - 3.70 \text{ h} - 2.92 \text{ h} - \frac{1 \text{ preheat} \times 15.6 \text{ min}}{60 \text{ min/h}}$$

$$t_i = 4.52 \text{ h}$$

The idle energy consumption is then calculated as follows:

$$E_{gas,i} = q_{gas,i} \times t_i$$

$$E_{gas,i} = 17,449 \text{ Btu/h} \times 4.52 \text{ h}$$

$$E_{gas,i} = 78,870 \text{ Btu}$$

Step 6—The total daily energy consumption is calculated as follows:

$$E_{gas,daily} = E_{gas,h} + E_{gas,m} + E_{gas,l} + E_{gas,i} + n_p \times E_{gas,p}$$

$$E_{gas,daily} = 27,521 \text{ Btu} + 123,169 \text{ Btu} + 72,393 \text{ Btu} + 78,870 \text{ Btu} + 1 \times 20,988 \text{ Btu}$$

$$E_{gas,daily} = 322,941 \text{ Btu/day} = 3.23 \text{ therms/day}$$

Step 7—The annual energy cost is calculated as follows:

$$Cost_{annual} = E_{gas,daily} \times R_{gas} \times Days$$

$$Cost_{annual} = 3.23 \text{ therms/day} \times 0.60 \text{ dollars/therm} \times 365 \text{ days/year}$$

$$Cost_{annual} = 707 \text{ dollars/year}$$